

User's Guide

Copyright and Trademarks

Copyright and Trademarks

No part of this publication may be reproduced, stored in a retrieval system, or transmitted in any form or by any means, electronic, mechanical, photocopying, recording, or otherwise, without the prior written permission of Seiko Epson Corporation. No patent liability is assumed with respect to the use of the information contained herein. Neither is any liability assumed for damages resulting from the use of the information herein. The information contained herein is designed only for use with this Epson product. Epson is not responsible for any use of this information as applied to other products.

Neither Seiko Epson Corporation nor its affiliates shall be liable to the purchaser of this product or third parties for damages, losses, costs, or expenses incurred by the purchaser or third parties as a result of accident, misuse, or abuse of this product or unauthorized modifications, repairs, or alterations to this product, or (excluding the U.S.) failure to strictly comply with Seiko Epson Corporation's operating and maintenance instructions.

Seiko Epson Corporation and its affiliates shall not be liable for any damages or problems arising from the use of any options or any consumable products other than those designated as Original Epson Products or Epson Approved Products by Seiko Epson Corporation.

Seiko Epson Corporation shall not be held liable for any damage resulting from electromagnetic interference that occurs from the use of any interface cables other than those designated as Epson Approved Products by Seiko Epson Corporation.

EPSON® is a registered trademark, and EPSON EXCEED YOUR VISION or EXCEED YOUR VISION is a trademark of Seiko Epson Corporation.

Intel® is a registered trademark of Intel Corporation.

Microsoft®, Windows®, and Windows Vista® are registered trademarks of Microsoft Corporation.

Apple, Macintosh, Mac OS, OS X, Bonjour and TrueType are trademarks of Apple Inc., registered in the U.S. and other countries.

Apple Chancery, Chicago, Geneva, Hoefler Text, Monaco and New York are trademarks or registered trademarks of Apple, Inc.

AirPrint is a trademark of Apple Inc.

Google Cloud Print™ is a registered trademark of Google Inc.

Monotype is a trademark of Monotype Imaging, Inc. registered in the United States Patent and Trademark Office and may be registered in certain jurisdictions.

Albertus, Arial, Gillsans, Times New Roman and Joanna are trademarks of The Monotype Corporation registered in the United States Patent and Trademark Office and may be registered in certain jurisdictions.

ITC Avant Garde, ITC Bookman, ITC Lubalin, ITC Mona Lisa Recut, ITC Symbol, ITC Zapf-Chancery, and ITC ZapfDingbats are trademarks of International Typeface Corporation registered in the United States Patent and Trademark Office and may be registered in certain jurisdictions.

Copyright and Trademarks

Clarendon, Helvetica, New Century Schoolbook, Optima, Palatino, Stempel Garamond, Times and Univers are registered trademarks of Heidelberger Druckmaschinen AG, which may be registered in certain jurisdictions, exclusively licensed through Linotype Library GmbH, a wholly owned subsidiary of Heidelberger Druckmaschinen AG.

Wingdings is a registered trademark of Microsoft Corporation in the United States and other countries.

Antique Olive is a registered trademark of Marcel Olive and may be registered in certain jurisdictions.

Adobe SansMM, Adobe SerifMM, Carta, and Tekton are registered trademarks of Adobe Systems Incorporated.

Marigold and Oxford are trademarks of AlphaOmega Typography.

Coronet is a registered trademark of Ludlow Type Foundry.

Eurostile is a trademark of Nebiolo.

Bitstream is a registered trademark of Bitstream Inc. registered in the United States Patent and Trademark Office and may be registered in certain jurisdictions.

Swiss is a trademark of Bitstream Inc. registered in the United States Patent and Trademark Office and may be registered in certain jurisdictions.

PCL is the registered trademark of Hewlett-Packard Company.

Adobe, Adobe Reader, PostScript3, Acrobat, and Photoshop are trademarks of Adobe systems Incorporated, which may be registered in certain jurisdictions.

Getopt

Copyright © 1987, 1993, 1994 The Regents of the University of California. All rights reserved.

Redistribution and use in source and binary forms, with or without modification, are permitted provided that the following conditions are met:

1. Redistributions of source code must retain the above copyright notice, this list of conditions and the following disclaimer.
2. Redistributions in binary form must reproduce the above copyright notice, this list of conditions and the following disclaimer in the documentation and/or other materials provided with the distribution.
4. Neither the name of the University nor the names of its contributors may be used to endorse or promote products derived from this software without specific prior written permission.

THIS SOFTWARE IS PROVIDED BY THE REGENTS AND CONTRIBUTORS "AS IS" AND ANY EXPRESS OR IMPLIED WARRANTIES, INCLUDING, BUT NOT LIMITED TO, THE IMPLIED WARRANTIES OF MERCHANTABILITY AND FITNESS FOR A PARTICULAR PURPOSE ARE DISCLAIMED. IN NO EVENT SHALL THE REGENTS OR CONTRIBUTORS BE LIABLE FOR ANY DIRECT, INDIRECT, INCIDENTAL, SPECIAL, EXEMPLARY, OR CONSEQUENTIAL DAMAGES (INCLUDING, BUT NOT LIMITED TO, PROCUREMENT OF SUBSTITUTE GOODS OR SERVICES; LOSS OF USE, DATA, OR PROFITS; OR BUSINESS INTERRUPTION) HOWEVER CAUSED AND ON ANY THEORY OF LIABILITY, WHETHER IN CONTRACT, STRICT LIABILITY, OR TORT (INCLUDING NEGLIGENCE OR OTHERWISE) ARISING IN ANY WAY OUT OF THE USE OF THIS SOFTWARE, EVEN IF ADVISED OF THE POSSIBILITY OF SUCH DAMAGE.

This code illustrates a sample implementation of the Arcfour algorithm

Copyright © April 29, 1997 Kalle Kaukonen. All Rights Reserved.

Redistribution and use in source and binary forms, with or without modification, are permitted provided that this copyright notice and disclaimer are retained.

Copyright and Trademarks

THIS SOFTWARE IS PROVIDED BY KALLE KAUKONEN AND CONTRIBUTORS "AS IS" AND ANY EXPRESS OR IMPLIED WARRANTIES, INCLUDING, BUT NOT LIMITED TO, THE IMPLIED WARRANTIES OF MERCHANTABILITY AND FITNESS FOR A PARTICULAR PURPOSE ARE DISCLAIMED. IN NO EVENT SHALL KALLE KAUKONEN OR CONTRIBUTORS BE LIABLE FOR ANY DIRECT, INDIRECT, INCIDENTAL, SPECIAL, EXEMPLARY, OR CONSEQUENTIAL DAMAGES (INCLUDING, BUT NOT LIMITED TO, PROCUREMENT OF SUBSTITUTE GOODS OR SERVICES; LOSS OF USE, DATA, OR PROFITS; OR BUSINESS INTERRUPTION) HOWEVER CAUSED AND ON ANY THEORY OF LIABILITY, WHETHER IN CONTRACT, STRICT LIABILITY, OR TORT (INCLUDING NEGLIGENCE OR OTHERWISE) ARISING IN ANY WAY OUT OF THE USE OF THIS SOFTWARE, EVEN IF ADVISED OF THE POSSIBILITY OF SUCH DAMAGE.

microSDHC Logo is a trademark of SD-3C, LLC. (WF-5190 Series only.)

Note: microSDHC is built into the product and cannot be removed.



General Notice: Other product names used herein are for identification purposes only and may be trademarks of their respective owners. Epson disclaims any and all rights in those marks.

© 2015 Seiko Epson Corporation. All rights reserved.

The contents of this manual and the specifications of this product are subject to change without notice.

Contents

Copyright and Trademarks

Copyright and Trademarks.	2
-----------------------------------	---

Introduction

Where to Find Information.	8
Available Features.	8
Caution, Important and Note.	8
Operating System Versions.	9
Using Epson Connect Service.	10

Important Instructions

Safety Instructions.	11
Product Advisories and Warnings.	11
Setting up/using the product.	11
Using the product with a wireless connection	13
Using the LCD screen.	13
Handling ink cartridges.	13

Getting to Know Your Product

Product Parts.	14
Guide to the Control Panel.	16
Icons.	16

Paper and Media Handling

Introduction to Using, Loading, and Storing Media.	18
Storing paper.	18
Selecting Paper.	18
Paper type settings on the LCD screen.	20
Paper type settings from the printer driver.	21
Loading Paper into the Paper Cassette.	22
Loading Paper and Envelopes into the Rear Paper Feed.	25

Printing

Printing from Your Computer.	28
Printer Driver and Status Monitor.	28
Basic Operations.	30

Basic printing.	30
Canceling printing.	34
Other Options.	35
Product presets (For Windows Only).	35
2-sided printing.	36
Fit to page printing.	38
Pages per Sheet printing.	39
Anti-Copy Pattern printing (for Windows Only).	40
Watermark printing (For Windows Only).	41
Header/Footer printing (For Windows Only)	42
Printing Confidential Jobs.	42
Administrator Settings for Printer Driver (for Windows Only).	43
Using the PostScript Printer Driver.	44
Using the Epson Universal Printer Driver.	44

Menu List of Control Panel

System Administration Settings.	46
---	----

Ink Cartridge and Consumable Information

Ink Cartridges.	51
Maintenance Box.	51

Replacing Ink Cartridges

Ink Cartridge Safety Instructions, Precautions, and Specifications.	52
Safety instructions.	52
Precautions on ink cartridge replacement.	52
Ink Cartridge Specifications.	53
Checking the Ink Cartridge Status.	54
For Windows.	54
For Mac OS X.	55
Using the control panel.	56
Temporary Printing with Black Ink When Color Ink Cartridges are Expended.	57
For Windows.	57
For Mac OS X.	59
Conserving Black Ink When the Cartridge Is Low (For Windows Only).	60
Replacing an ink cartridge.	61

Contents

Maintaining Your Product and Software

Installing Option.	64
Paper Cassette Unit.	64
Checking the Print Head Nozzles.	65
Using the Nozzle Check utility for Windows	65
Using the Nozzle Check utility for Mac OS X	66
Using the control panel.	66
Cleaning the Print Head.	67
Using the Head Cleaning utility for Windows	68
Using the Head Cleaning utility for Mac OS X	68
Using the control panel.	68
Aligning the Print Head.	69
Using the Print Head Alignment utility for Windows.	69
Using the Print Head Alignment utility for Mac OS X.	69
Using the control panel.	70
Making Network Service Settings.	71
Web Config.	71
Sharing the Product for Printing.	72
Cleaning the Product.	72
Cleaning the exterior of the product.	72
Cleaning the interior of the product.	72
Replacing Maintenance Box.	73
Checking the maintenance box status.	73
Handling precautions.	73
Replacing a maintenance box.	73
Transporting the Product.	75
Checking and Installing Your Software.	76
Checking the software installed on your computer.	76
Installing the software.	77
Installing the PostScript Printer Driver.	77
System requirements.	77
Installing the PostScript printer driver with Windows.	77
Installing the PostScript printer driver with Mac OS X.	80
Installing the Epson Universal Printer Driver (for Windows Only).	80
Computer system requirements.	81
Installing the Printer Driver.	81
Uninstalling Your Software.	81

For Windows.	81
For Mac OS X.	83

Error Indicators

Error Messages on the Control Panel.	84
--	----

Troubleshooting for Printing

Diagnosing the Problem.	85
Checking product status.	86
Paper Jams.	88
Removing jammed paper from the rear unit.	89
Removing jammed paper from the front cover and the output tray.	90
Removing jammed paper from the paper cassette.	90
Preventing paper jams.	91
Reprinting after a paper jam (for Windows only).	92
Print Quality Help.	92
Horizontal banding.	93
Vertical banding or misalignment.	93
Incorrect or missing colors.	94
Blurry or smeared print.	94
Miscellaneous Printout Problems.	95
Incorrect or garbled characters.	95
Incorrect margins.	95
Printout has a slight slant.	96
Inverted image.	96
Blank pages print.	96
Printed side is smeared or scuffed.	96
Printing is too slow.	97
Paper Does Not Feed Correctly.	97
Paper does not feed.	97
Multiple pages feed.	98
Paper Cassette 2 is not displayed on the printer driver.	98
Paper is improperly loaded.	98
Paper is not ejected fully or is wrinkled.	98
The Product Does Not Print.	99
All lights are off.	99
Lights came on and then went out.	99
The control panel or lights are on.	99
Using the PostScript Printer Driver.	99
The product does not print.	100
The product does not print correctly.	100
Miscellaneous printout problems.	100
Printing takes time.	100
Other Problem.	100

Printing plain papers quietly.	100
--	-----

Product Information

System Requirements.	102
For Windows.	102
For Mac OS X.	102
Technical Specifications.	102
Printer specifications.	102
Network interface specification.	105
Mechanical.	105
Electrical.	106
Environmental.	107
Standards and approvals.	107
Interface.	108
Option.	108
Font Information.	108
Available fonts.	109
PCL5 mode.	110
PCL6 mode.	112
Introduction to symbol sets.	113

Where To Get Help

Technical Support Web Site.	119
Contacting Epson Support.	119
Before Contacting Epson.	119
Help for Users in Europe.	120
Help for Users in Taiwan.	120
Help for Users in Australia.	121
Help for Users in Singapore.	121
Help for Users in Thailand.	122
Help for Users in Vietnam.	122
Help for Users in Indonesia.	122
Help for Users in Malaysia.	123
Help for Users in the Philippines.	124

Index

Introduction

Where to Find Information

The latest version of the following manuals are available on the Epson support website.

<http://www.epson.eu/Support> (Europe)

<http://support.epson.net/> (outside Europe)

Start Here (paper):

Provides you with an introduction to the product and services.

Important Safety Instructions (paper):

Provides you with instructions to ensure the safe use of this product. This manual may not be included depending on model and region.

User's Guide (PDF):

Provides you with detailed operating, safety, and troubleshooting instructions. See this guide when using this product with a computer, or when using advanced features.

Network Guide (PDF):

Provides instructions on network settings for your computer, smartphone or product, and solving problems.

Administrator's Guide (PDF):

Provides the system administrator with information on security management and product settings.

Available Features

Check what is available for your product.

	WF-5110 WF-5111	WF-5190 WF-5191
Print	✓	✓
Print (PS3/PCL)	-	✓
Confidential job printing	-	✓

Caution, Important and Note

Caution, Important, and Note in this manual are indicated as below and have the following meaning.

Introduction



Caution

must be followed carefully to avoid bodily injury.



Important

must be observed to avoid damage to your equipment.

Note

contain useful tips and restrictions on product operation.

Operating System Versions

In this manual, the following abbreviations are used.

- Windows 8 refers to Windows 8, Windows 8 Pro, Windows 8 Enterprise.
- Windows 7 refers to Windows 7 Home Basic, Windows 7 Home Premium, Windows 7 Professional, and Windows 7 Ultimate.
- Windows Vista refers to Windows Vista Home Basic Edition, Windows Vista Home Premium Edition, Windows Vista Business Edition, Windows Vista Enterprise Edition, and Windows Vista Ultimate Edition.
- Windows XP refers to Windows XP Home Edition, Windows XP Professional x64 Edition, and Windows XP Professional.
- Windows Server 2012 refers to Windows Server 2012 Essentials Edition, Server 2012 standard Edition.
- Windows Server 2008 refers to Windows Server 2008 Standard Edition, Windows Server 2008 Enterprise Edition, Windows Server 2008 x64 Standard Edition, and Windows Server 2008 x64 Enterprise Edition.
- Windows Server 2008 R2 refers to Windows Server 2008 R2 Standard Edition and Windows Server 2008 R2 Enterprise Edition.
- Windows Server 2003 refers to Windows Server 2003 Standard Edition, Windows Server 2003 Enterprise Edition, Windows Server 2003 x64 Standard Edition, Windows Server 2003 x64 Enterprise Edition, Windows Server 2003 R2 Standard Edition, Windows Server 2003 R2 Standard x64 Edition, Windows Server 2003 R2 Enterprise Edition and Windows Server 2003 R2 Enterprise x64 Edition.
- Mac OS X refers to Mac OS X 10.5.8, 10.6.x, 10.7.x, 10.8.x.

Using Epson Connect Service

Using Epson Connect and other companies' services, you can easily print directly from your smartphone, tablet PC or laptop, anytime and practically anywhere even across the globe! For more information about the printing and other services, visit the following URL;

<https://www.epsonconnect.com/> (Epson Connect portal site)

<http://www.epsonconnect.eu> (Europe only)



Note:

You can make network service settings using a Web browser on your computer, smartphone, tablet PC, or laptop that is connected to the same network as the product.

➔ [“Making Network Service Settings” on page 71](#)

Important Instructions

Important Instructions

Safety Instructions

Read and follow these instructions to ensure safe use of this product. Make sure you keep this guide for future reference. Also, be sure to follow all warnings and instructions marked on the product.

- ❑ Use only the power cord supplied with the product and do not use the cord with any other equipment. Use of other cords with this product or the use of the supplied power cord with other equipment may result in fire or electric shock.
- ❑ Be sure your AC power cord meets the relevant local safety standard.
- ❑ Never disassemble, modify, or attempt to repair the power cord, plug, printer unit, or options by yourself, except as specifically explained in the product's guides.
- ❑ Unplug the product and refer servicing to qualified service personnel under the following conditions:
The power cord or plug is damaged; liquid has entered the product; the product has been dropped or the casing damaged; the product does not operate normally or exhibits a distinct change in performance. Do not adjust controls that are not covered by the operating instructions.
- ❑ Place the product near a wall outlet where the plug can be easily unplugged.
- ❑ Do not place or store the product outdoors, near excessive dirt or dust, water, heat sources, or in locations subject to shocks, vibrations, high temperature or humidity.
- ❑ Take care not to spill liquid on the product and not to handle the product with wet hands.
- ❑ Keep this product at least 22 cm away from cardiac pacemakers. Radio waves from this product may adversely affect the operation of cardiac pacemakers.
- ❑ If the LCD screen is damaged, contact your dealer. If the liquid crystal solution gets on your hands, wash them thoroughly with soap and water. If the liquid crystal solution gets into your eyes, flush them immediately with water. If discomfort or vision problems remain after a thorough flushing, see a doctor immediately.

Note:

The following provides safety instructions for ink cartridges.

➔ ["Replacing Ink Cartridges" on page 52](#)

Product Advisories and Warnings

Read and follow these instructions to avoid damaging the product or your property. Make sure you keep this guide for future reference.

Setting up/using the product

- ❑ Do not block or cover the vents and openings in the product.

Important Instructions

- ❑ Use only the type of power source indicated on the product's label.
- ❑ Avoid using outlets on the same circuit as photocopiers or air control systems that regularly switch on and off.
- ❑ Avoid electrical outlets controlled by wall switches or automatic timers.
- ❑ Keep the entire computer system away from potential sources of electromagnetic interference, such as loudspeakers or the base units of cordless telephones.
- ❑ The power-supply cords should be placed to avoid abrasions, cuts, fraying, crimping, and kinking. Do not place objects on top of the power-supply cords and do not allow the power-supply cords to be stepped on or run over. Be particularly careful to keep all the power-supply cords straight at the ends and the points where they enter and leave the transformer.
- ❑ If you use an extension cord with the product, make sure that the total ampere rating of the devices plugged into the extension cord does not exceed the cord's ampere rating. Also, make sure that the total ampere rating of all devices plugged into the wall outlet does not exceed the wall outlet's ampere rating.
- ❑ If you plan to use the product in Germany, the building installation must be protected by a 10 or 16 amp circuit breaker to provide adequate short-circuit protection and over-current protection for the product.
- ❑ When connecting the product to a computer or other device with a cable, ensure the correct orientation of the connectors. Each connector has only one correct orientation. Inserting a connector in the wrong orientation may damage both devices connected by the cable.
- ❑ Place the product on a flat, stable surface that extends beyond the base of the product in all directions. The product will not operate properly if it is tilted at an angle.
- ❑ When storing or transporting the product, avoid tilting it, placing it vertically, or turning it upside down; otherwise ink may leak.
- ❑ Leave enough space in front of the product for the paper to be fully ejected.
- ❑ Avoid places subject to rapid changes in temperature and humidity. Also, keep the product away from direct sunlight, strong light, or heat sources.
- ❑ Do not insert objects through the slots in the product.
- ❑ Do not put your hand inside the product during printing.
- ❑ Do not touch the white flat cable inside the product.
- ❑ Do not use aerosol products that contain flammable gases inside or around the product. Doing so may cause fire.
- ❑ Do not move the print head by hand; otherwise, you may damage the product.
- ❑ Always turn the product off using the ⏻ button. Do not unplug the product or turn off the power at the outlet until the LCD screen has turned off completely.
- ❑ Before transporting the product, make sure that the print head is in the home (far right) position and the ink cartridges are inserted into the slots.
- ❑ If you are not going to use the product for a long period, be sure to unplug the power cord from the electrical outlet.

Important Instructions

Using the product with a wireless connection

- ❑ Radio waves from this product may negatively affect the operation of medical electronic equipment, causing them to malfunction. When using this product inside medical facilities or near medical equipment, follow directions from the authorized personnel representing the medical facilities, and follow all posted warnings and directions on the medical equipment.
- ❑ Radio waves from this product may negatively affect the operation of automatically controlled devices such as automatic doors or fire alarms, and could lead to accidents due to malfunction. When using this product near automatically controlled devices, follow all posted warnings and directions on these devices.

Using the LCD screen

- ❑ The LCD screen may contain a few small bright or dark spots, and because of its features it may have an uneven brightness. These are normal and do not indicate that it is damaged in any way.
- ❑ Only use a dry, soft cloth to clean the LCD screen or touchscreen. Do not use liquid or chemical cleaners.
- ❑ The exterior cover of the LCD screen could break if it receives a heavy impact. Contact your dealer if the panel surface chips or cracks, and do not touch or attempt to remove the broken pieces.

Handling ink cartridges

We will provide ink-related safety instructions and product advice/warnings in the linked section (before “Replacing Ink Cartridges” section).

➔ [“Replacing Ink Cartridges” on page 52](#)

Getting to Know Your Product

Note:

The illustrations in this manual are from a similar product model. Although they may differ from your actual product, the method of operation is the same.

Product Parts

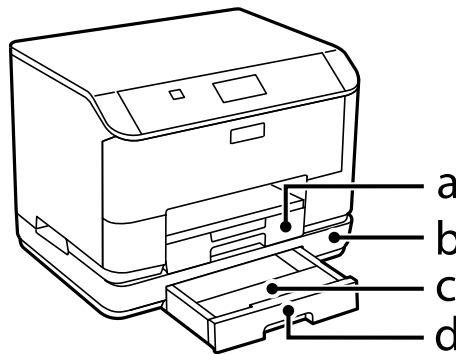

a.	Paper cassette 1
b.	Optional paper cassette unit
c.	Paper cassette cover (optional)
d.	Paper cassette 2 (optional)

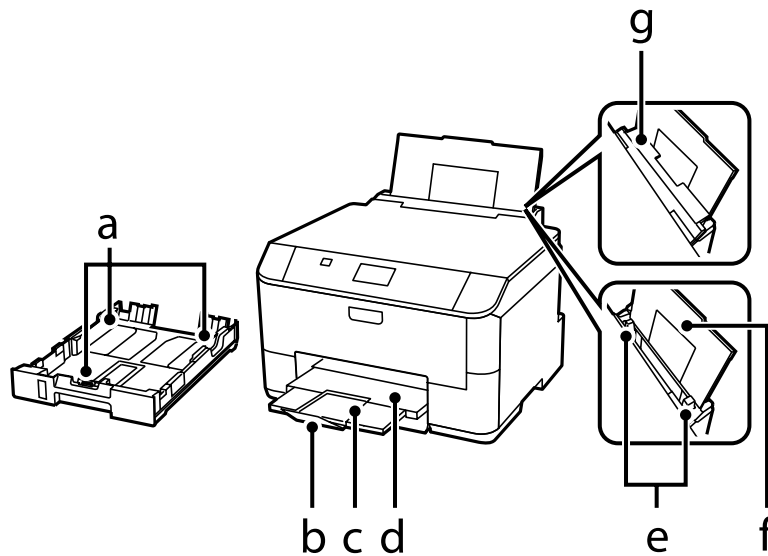

a.	Edge guides
----	-------------

Getting to Know Your Product

b.	Stopper
c.	Output tray extension
d.	Output tray
e.	Edge guides
f.	Rear paper feed
g.	Feeder guard

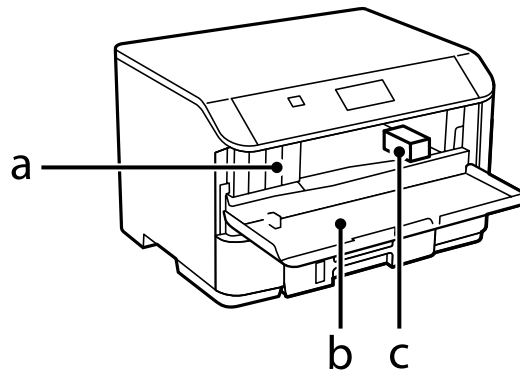

a.	Ink cartridge slots
b.	Front cover
c.	Print head

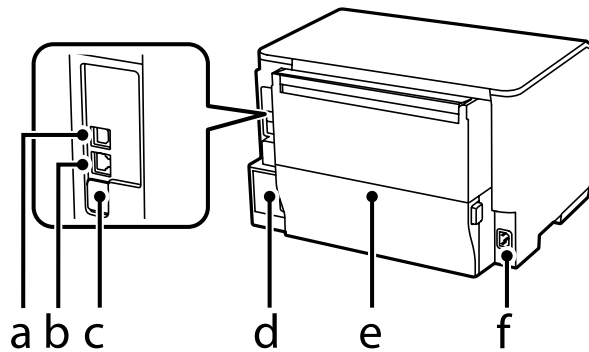

a.	USB port
b.	LAN port
c.	Service USB port*
d.	Maintenance box
e.	Rear cover
f.	AC inlet

* USB port for future use. Do not remove the sticker.

Guide to the Control Panel

Note:

- ❑ Control panel design varies depending on location.
- ❑ Although the control panel design and what displayed on the LCD screen such as menu names and option names may differ from your actual product, the method of operation is the same.

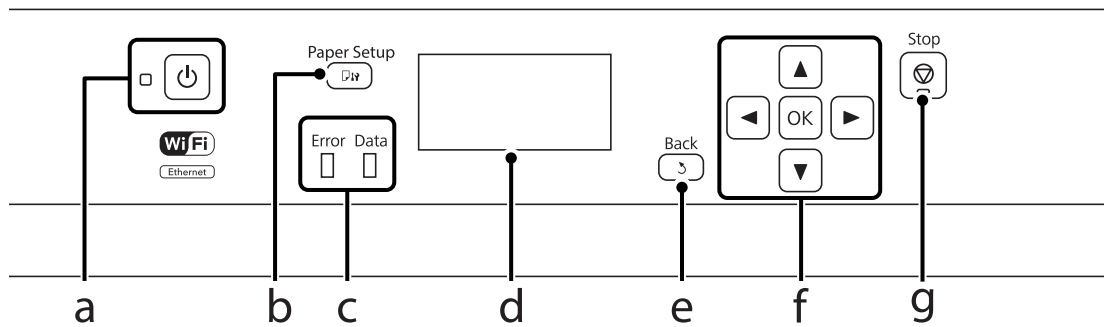







	Buttons/Lights	Function
a		Turns the product on or off. The power light turns on when the product is on. Flashes when the product is printing, replacing an ink cartridge, charging ink, or cleaning the print head.
b		Press this to select the size and type of paper you loaded in the paper cassette or rear paper feed.
c	Error	The orange light on the left turns on or flashes when an error occurs.
	Data	The blue light on the right flashes while the product is processing data. It stays on when there are print jobs waiting to be processed.
d	-	LCD screen displays menus.
e		Cancels/returns to the previous menu.
f		Press , , , to select menus. Press OK to confirm your selection and go to next screen.
g		Stops the current operation.

Icons

The following icons are displayed on the control panel depending on the product's status.

Icons	Description
	Indicates that there is no Ethernet connection.
	Indicates that an Ethernet connection has been established.

Getting to Know Your Product

Icons	Description
	Indicates that a Wi-Fi network error has occurred or the product is searching for a connection.
	Indicates that a Wi-Fi connection has been established. The number of bars indicates the connection's signal strength.
	Indicates that an Ad Hoc connection has been established.
	Indicates that a Wi-Fi Direct mode connection has been established.
	Indicates that Simple AP mode connection has been established.
	Indicates that one of the Eco Mode functions is on.

Paper and Media Handling

Introduction to Using, Loading, and Storing Media

You can achieve good results with most types of plain paper. However, coated papers provide superior prints because they absorb less ink.

Epson provides special papers that are formulated for the ink used in Epson ink jet products, and recommends these papers to ensure high-quality results.

When loading special paper distributed by Epson, read the instruction sheets packed with the paper first and keep the following points in mind.

Note:

- ❑ *Load the paper into the paper cassette printable side down. The printable side is usually whiter or glossier. See the instruction sheets packed with the paper for more information. Some types of paper have cut corners to help identify the correct loading direction.*
- ❑ *If the paper is curled, flatten it or curl it slightly in the opposite direction before loading. Printing on curled paper may cause ink to smear on your prints.*



Storing paper

Return unused paper to the original package as soon as you finish printing. When handling special media, Epson recommends storing your prints in a resealable plastic bag. Keep unused paper and prints away from high temperature, humidity, and direct sunlight.

Selecting Paper

The following table shows supported paper types. The loading capacity and paper source vary by paper as shown below.

Paper and Media Handling

Media Type	Size	Loading capacity (sheets or height)			Automatic 2-sided printing
		Paper cassette 1 or Paper cassette	Paper cassette 2* ¹	Rear paper feed	
Plain Paper* ²	Legal	27.5 mm	27.5 mm	1	-
	Letter	27.5 mm	27.5 mm	80* ³	✓
	A4	27.5 mm	27.5 mm	80* ³	✓
	B5	27.5 mm	27.5 mm	80* ³	✓
	A5	27.5 mm	-	80* ³	-
	Executive	-	-	80* ³	-
	A6	-	-	80* ³	-
	User Defined (182 x 257 mm to 215.9 x 297 mm)	-	-	80* ³	✓
	User Defined (other than above)	-	-	1	-
Thick paper* ⁴	Legal	-	-	1	-
	Letter	-	-	10* ⁵	-
	A4	-	-	10* ⁵	-
	B5	-	-	10* ⁵	-
	A5	-	-	10* ⁵	-
	Executive	-	-	10* ⁵	-
	A6	-	-	10* ⁵	-
	User Defined (182 x 257 mm to 215.9 x 297 mm)	-	-	10* ⁵	-
	User Defined (other than above)	-	-	1	-
Envelope	#10	-	-	10	-
	DL	-	-	10	-
	C4	-	-	1	-
	C6	-	-	10	-
Epson Bright White Ink Jet Paper	A4	200	200	50* ⁶	✓
Epson Photo Quality Ink Jet Paper	A4	-	-	80	-

Paper and Media Handling

Media Type	Size	Loading capacity (sheets or height)			Automatic 2-sided printing
		Paper cassette 1 or Paper cassette	Paper cassette 2* ¹	Rear paper feed	
Epson Matte Paper - Heavyweight	A4	-	-	20	-
Epson Premium Glossy Photo Paper	A4	-	-	20	-
	13 × 18 cm (5 × 7 in.)	-	-	20	-
	10 × 15 cm (4 × 6 in.)	-	-	20	-
	16:9 Wide (102 × 181 mm)	-	-	20	-
Epson Premium Semigloss Photo Paper	A4	-	-	20	-
	10 × 15 cm (4 × 6 in.)	-	-	20	-
Epson Ultra Glossy Photo Paper	A4	-	-	20	-
	13 × 18 cm (5 × 7 in.)	-	-	20	-
	10 × 15 cm (4 × 6 in.)	-	-	20	-
Epson Photo Paper, Glossy	A4	-	-	20	-
	13 × 18 cm (5 × 7 in.)	-	-	20	-
	10 × 15 cm (4 × 6 in.)	-	-	20	-

*1 Depending on the product, Paper cassette 2 is an optional extra.

*2 Plain paper is defined as paper with a weight of 64 g/m² (17 lb) to 90 g/m² (24 lb).

It includes preprinted paper, letterhead, colored paper, and recycled paper.

*3 The loading capacity for manual 2-sided printing is 30 sheets.

*4 Thick paper is defined as paper with a weight of 91 g/m² (25 lb) to 256 g/m² (68 lb).

*5 The loading capacity for manual 2-sided printing is 5 sheets.

*6 The loading capacity for manual 2-sided printing is 20 sheets.

Note:

- The availability of paper varies by location.
- When printing on genuine Epson paper at a user defined size, only Standard or Normal print quality settings are available. Although some printer drivers allow you to select a better print quality, the printouts are printed using Standard or Normal.

Paper type settings on the LCD screen

The product automatically adjusts itself for the type of paper you select in your print settings. That is why the paper type setting is so important. It tells your product what kind of paper you are using and adjusts the ink coverage accordingly. The table below lists the settings you should choose for your paper.

Paper and Media Handling

For this paper	LCD paper type
Plain paper*1	plain papers
Preprinted paper *1	Preprinted
Letterhead*1	Letterhead
Colored paper*1	Color
Recycled paper*1	Recycled
Epson Bright White Ink Jet Paper*1	plain papers
Epson Ultra Glossy Photo Paper	Ultra Glossy
Epson Premium Glossy Photo Paper	Prem. Glossy
Epson Premium Semigloss Photo Paper	Prem. Semigloss
Epson Photo Paper, Glossy	Glossy
Epson Matte Paper – Heavyweight	Matte
Epson Photo Quality Ink Jet Paper	Matte
Thick paper	Thick -Paper
Envelopes	Envelope

*1 You can perform 2-sided printing with this paper.

Paper type settings from the printer driver

The product automatically adjusts itself for the type of paper you select in your print settings. That is why the paper type setting is so important. It tells your product what kind of paper you are using and adjusts the ink coverage accordingly. The table below lists the settings you should choose for your paper.

For this paper	Printer driver paper type
Plain paper	plain papers
Epson Bright White Ink Jet Paper	plain papers
Preprinted paper	Preprinted
Letterhead	Letterhead
Colored paper	Color
Recycled paper	Recycled
Epson Ultra Glossy Photo Paper	Epson Ultra Glossy
Epson Premium Glossy Photo Paper	Epson Premium Glossy
Epson Premium Semigloss Photo Paper	Epson Premium Semigloss
Epson Photo Paper, Glossy	Photo Paper Glossy

Paper and Media Handling

For this paper	Printer driver paper type
Epson Matte Paper – Heavyweight	Epson Matte
Epson Photo Quality Ink Jet Paper	Epson Matte
Thick paper	Thick-Paper
Envelopes	Envelope

Note:

The availability of special media varies by location. For the latest information on media available in your area, contact Epson support.

➔ [“Technical Support Web Site” on page 119](#)

Loading Paper into the Paper Cassette

Follow these steps to load paper:

- 1 Pull the paper cassette all the way out.

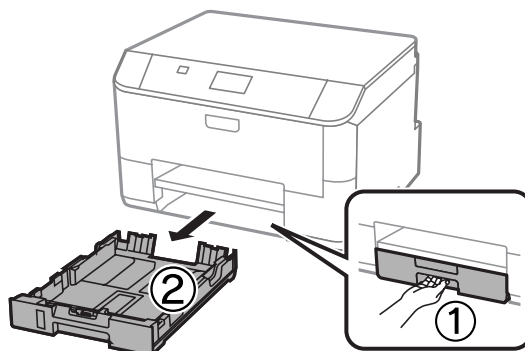

Note:

When you are loading paper in paper cassette 2, remove the paper cassette cover.

- 2 Pinch and slide the edge guides to the sides of the paper cassette.

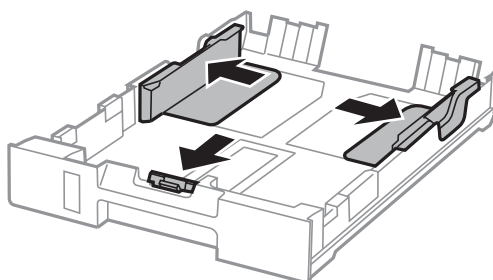

Paper and Media Handling

Note:

When using Legal-size paper, extend the paper cassette as shown in the illustration.

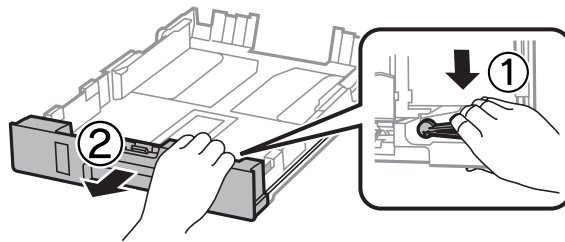

3

Slide the edge guide to adjust to the paper size you will use.

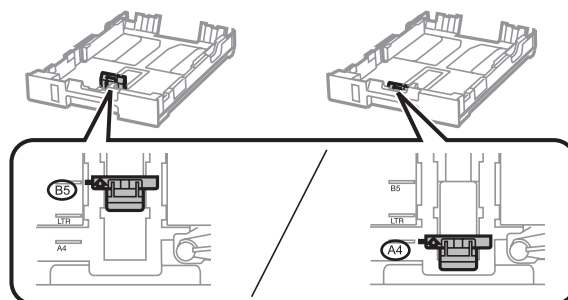

4

Load paper toward the edge guide with printable side face down, and check that the paper is not sticking out from the end of the cassette.

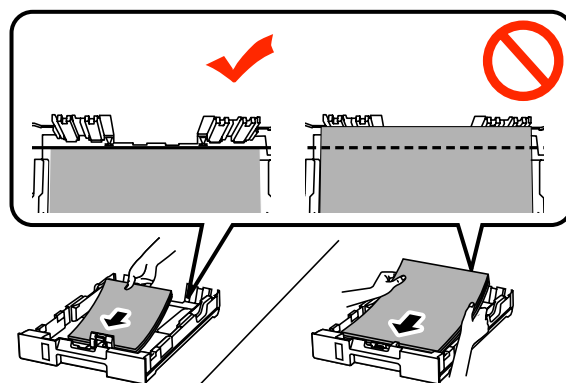

Note:

- ❑ Fan and align the edges of the paper before loading.
- ❑ If you want to print on commercially available pre-punched paper, see [“Loading Paper and Envelopes into the Rear Paper Feed”](#) on page 25.

Paper and Media Handling

- 5** Slide the edge guides to the edges of the paper.

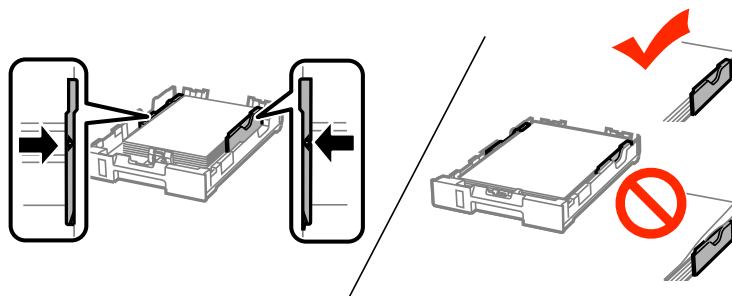

Note:

- For plain paper, do not load paper above the ▼ arrow mark inside the edge guide.
For Epson special media, make sure the number of sheets is less than the limit specified for the media.
- ➔ [“Selecting Paper” on page 18](#)
- When you are loading paper in paper cassette 2, reattach the paper cassette cover.

- 6** Keep the cassette flat and slowly and carefully reinsert it all the way into the product.

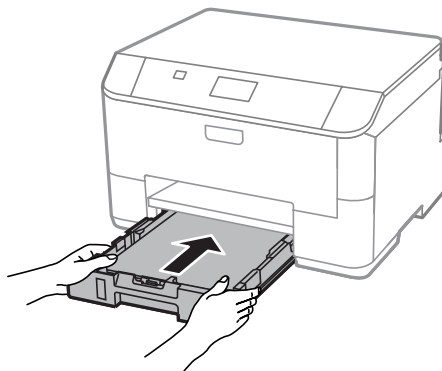

Note:

When you insert the paper cassette, the screen for making paper size and paper type settings is automatically displayed. Make sure the paper settings match the paper you have loaded.

- 7** Slide out the output tray and raise the stopper.

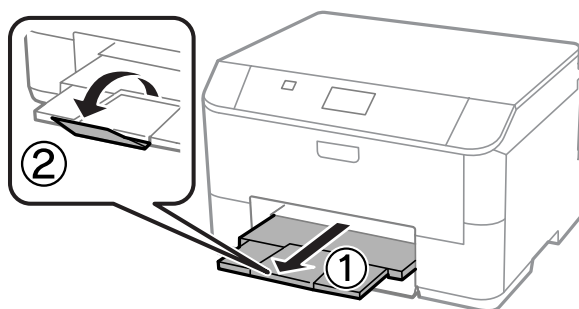

Paper and Media Handling

Note:

- ❑ Leave enough space in front of the product for the paper to be fully ejected.
- ❑ Do not remove or insert the paper cassette while the product is operating.

Loading Paper and Envelopes into the Rear Paper Feed

Follow the steps below to load paper and envelopes into the rear paper feed:

- 1** Slide out the output tray, and raise the stopper.

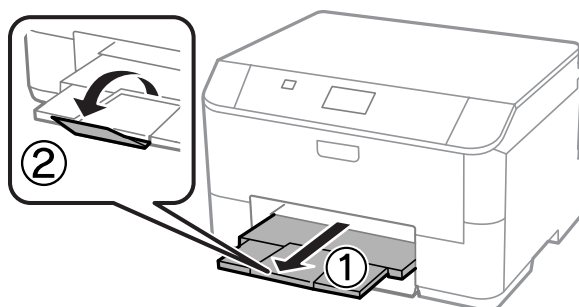

- 2** Pull up the paper support.

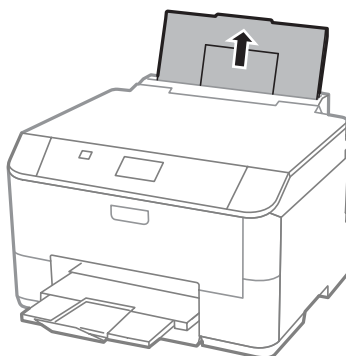

- 3** Open the feeder guard and then pinch and slide the edge guides.

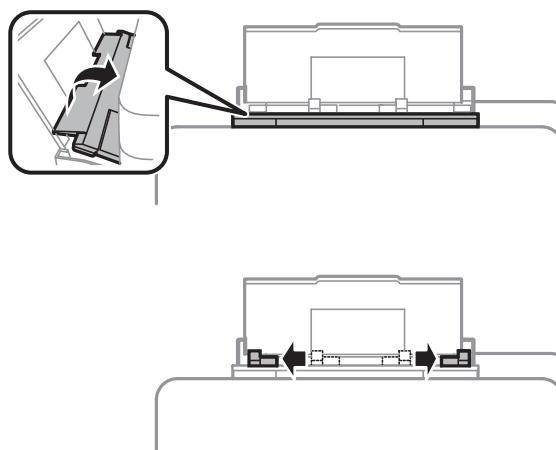

Paper and Media Handling

- 4** Load paper with the printable side up, at the center of the rear paper feed.

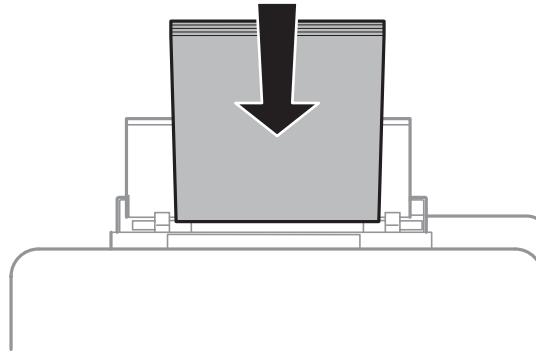

Note:

- The printable side is often whiter or brighter than the other side.
- When loading envelopes, load the short edge first with the flap facing down.

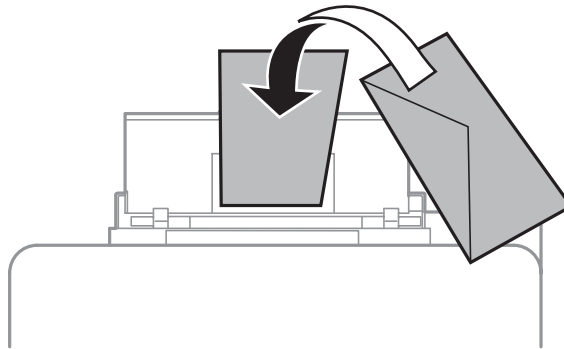

- Do not use envelopes that are curled or folded.
- Flatten the envelope and the flaps before loading.

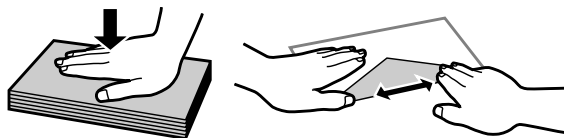

- Flatten the leading edge of the envelope before loading.
- Avoid using envelopes that are too thin, as they may curl during printing.

Paper and Media Handling

Note for paper with binding holes:

You can use pre-punched paper with binding holes on one of the long edges. Do not load the paper with the binding holes along the top or the bottom.

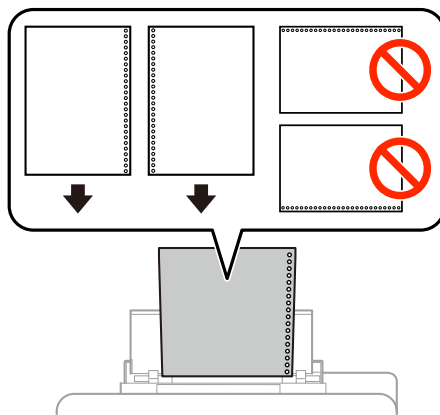

- Available sizes are A4, A5, B5, Letter and Legal.
- Load one sheet of paper at a time.
- Automatic 2-sided printing is not available.
- Make sure you adjust the print position of your file to avoid printing over the binder holes.

5

Slide the edge guide to the edge of the paper, but not too tightly.

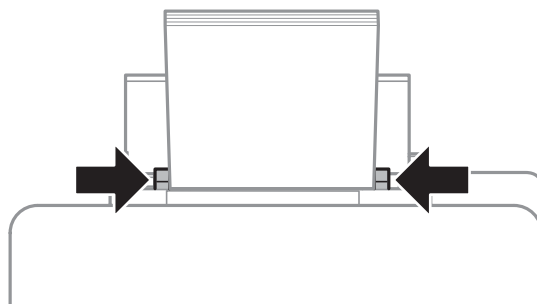

6

Press the  button, and then select **Rear Paper Feed**. Select the size and type of paper you loaded into the rear paper feed.

Printing

Printing from Your Computer

Printer Driver and Status Monitor

The printer driver lets you choose from a wide variety of settings to get the best printing results. The status monitor and the printer utilities help you check the product and keep it in top operating condition.

Note for Windows users:

- ❑ Your printer driver automatically finds and installs the latest version of the printer driver from Epson's Web site. Click the **Software Update** button in your printer driver's **Maintenance** window, and then follow the on-screen instructions. If the button does not appear in the **Maintenance** window, point at **All Programs** or **Programs** in the Windows Start menu, and check in the **EPSON** folder.*
 - * For Windows 8:
If the button does not appear in the **Maintenance** window, right-click on the **Start** screen, or swipe from the bottom or top edge of the **Start** screen and select **All apps**, then select **Software Update** from **EPSON** category.
- ❑ If you want to change the language of the driver, select the language you want to use from the **Language** setting in your printer driver's **Maintenance** window. Depending on the location, this function may not be available.

Accessing the printer driver for Windows

You can access the printer driver from most Windows applications, the desktop or the taskbar.

To make settings that apply only to the application you are using, access the printer driver from that application.

To make settings that apply to all of your Windows applications, access the printer driver from the desktop or the taskbar.

Refer to the following sections to access the printer driver.

Note:

Screen shots of the printer driver windows in this User's Guide are from Windows 7.

From Windows applications

- 1 Click **Print** or **Print Setup** on the File menu.
- 2 In the window that appears, click **Printer**, **Setup**, **Options**, **Preferences**, or **Properties**. (Depending on your application, you may need to click one or a combination of these buttons.)

From the desktop

- ❑ **Windows 8 and Server 2012**
Select **Desktop**, **Settings** charm, and **Control Panel**. Then select **Devices and Printers** from the **Hardware and Sound** category. Right-click on the product, or press and hold the product and select **Printing preferences**.

Printing

- ❑ **Windows 7 and Server 2008 R2:**
Click the start button, select **Devices and Printers**. Then right-click the product and select **Printing preferences**.
- ❑ **Windows Vista and Server 2008:**
Click the start button, select **Control Panel**, and then select **Printer** from the **Hardware and Sound** category. Then right-click the product and select **Printing preferences**.
- ❑ **Windows XP and Server 2003:**
Click **Start**, **Control Panel**, (**Printers and Other Hardware**), then **Printers and Faxes**. Select the product, then click **Printing Preferences** on the File menu.

From the shortcut icon on the taskbar

Right-click the product icon on the taskbar, then select **Printer Settings**.

To add a shortcut icon to the Windows taskbar, first access the printer driver from the desktop as described above. Next, click the **Maintenance** tab, and then click the **Extended Settings** button. In the Extended Settings window, select **Enable EPSON Status Monitor 3**, and then press **OK**.

Next, click the **Monitoring Preferences** button on the Maintenance tab, and then select **Register the shortcut icon to the task bar**.

Getting information through online help

In the printer driver window, try one of the following procedures.

- ❑ Right-click the item, then click **Help**.
- ❑ Click the  button at the top right of the window, then click the item (for Windows XP only).

Accessing printer properties for Windows

- ❑ **Windows 8 and Server 2012:**
Select **Desktop**, **Settings** charm, and then **Control Panel**. Next, select **Devices and Printers** from the **Hardware and Sound** category. Right-click on the product, or press and hold the product, and then select **Printer properties**.
- ❑ **Windows 7 and Server 2008 R2:**
Click the start button, select **Devices and Printers**, and then right-click the product and select **Printer properties**.
- ❑ **Windows Vista and Server 2008:**
Click the start button, select **Control Panel**, and then select **Printer** from the **Hardware and Sound** category. Then right-click the product and select **Properties**.
- ❑ **Windows XP and Server 2003:**
Click **Start**, **Control Panel**, (**Printers and Other Hardware**), and then **Printers and Faxes**. Select the product, and then click **Properties** on the File menu.

Accessing the printer driver for Mac OS X

The table below describes how to access the printer driver dialog.

Printing

Dialog Box	How to Access It
Page Setup	Click Page Setup on the File menu of your application. <i>Note:</i> <i>Depending on your application, the Page Setup menu may not appear in the File menu.</i>
Print	Click Print on the File menu of your application.
Epson Printer Utility 4	For Mac OS X 10.8 or 10.7, click System Preferences on the Apple menu and then click Print & Scan . Select your product from the Printers list box, click Options & Supplies, Utility , and then click Open Printer Utility . For Mac OS X 10.6, click System Preferences on the Apple menu and then click Print & Fax . Select your product from the Printers list box, click Options & Supplies, Utility , and then click Open Printer Utility . For Mac OS X 10.5, click System Preferences on the Apple menu and then click Print & Fax . Select your product from the Printers list box, click Open Print Queue and then click Utility button.

Basic Operations

Basic printing

Follow the steps below to print from your computer.

If you cannot change some of the printer driver settings, they may have been locked by the administrator. Contact your administrator or a power user for assistance.

Note:

- The screen shots in this manual may vary depending on the model.*
- Before you print, load paper properly.*
 - ➔ *“Loading Paper into the Paper Cassette” on page 22*
 - ➔ *“Loading Paper and Envelopes into the Rear Paper Feed” on page 25*
- Refer to the section below for the printable area.*
 - ➔ *“Printable area” on page 103*
- After completing the settings, print one test copy and examine the results before printing an entire job.*

Basic product settings for Windows

- 1** Open the file you want to print.

Printing

- 2 Access the printer settings.
➔ “Accessing the printer driver for Windows” on page 28

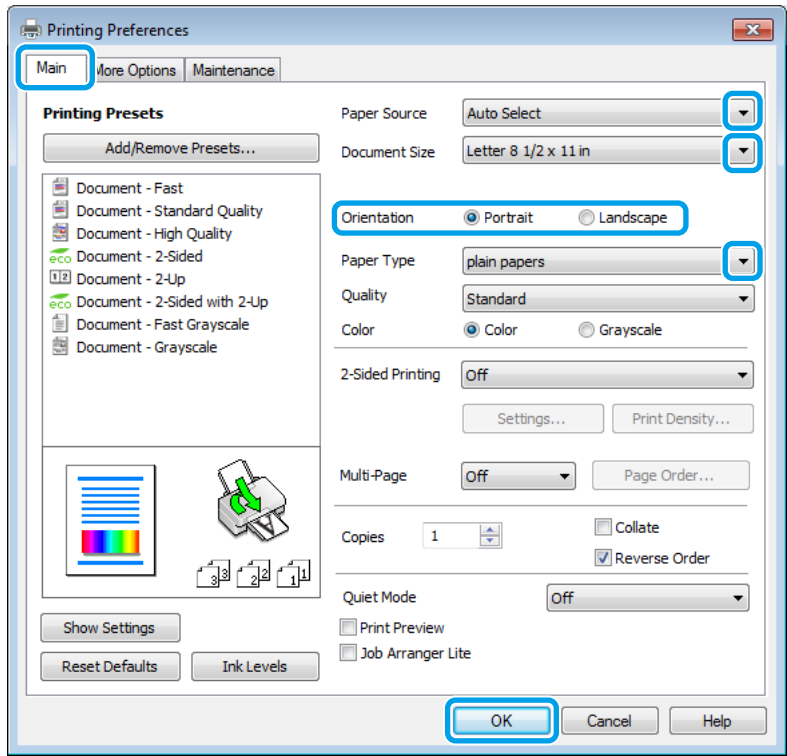

- 3 Click the **Main** tab.
- 4 Select the appropriate Paper Source setting.
- 5 Select the appropriate Document Size setting. You can also define a custom paper size. For details, see the online help.
- 6 Select **Portrait** (tall) or **Landscape** (wide) to change the orientation of your print.

Note:
Select **Landscape** when printing on envelopes.

- 7 Select the appropriate Paper Type setting.
➔ “Paper type settings from the printer driver” on page 21

Note:
Print quality is automatically adjusted for the selected Paper Type.

Printing

- 8 Select the appropriate Quality setting.

Note:

If you are printing high-density data on plain paper, letterhead, or preprinted paper, select Standard-Vivid to make your printout vivid.

- 9 Click **OK** to close the printer settings window.

Note:

To make changes to advanced settings, refer to the relevant section.

- 10 Print your file.

Basic product settings for Mac OS X

Note:

Screen shots of the printer driver windows in this manual are from Mac OS X 10.7.

- 1 Open the file you want to print.
- 2 Access the Print dialog box.
➔ [“Accessing the printer driver for Mac OS X” on page 29](#)

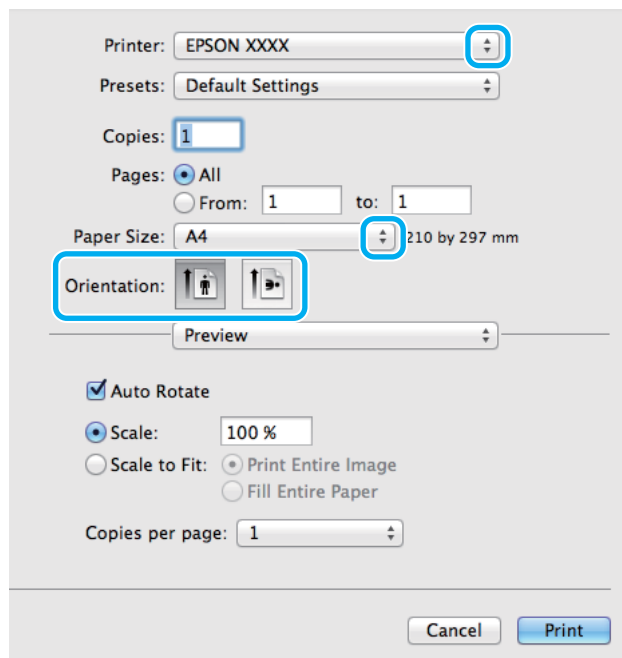

Note:

If the simplified dialog box is displayed, click the **Show Details** button (for Mac OS X 10.8 or 10.7) or the ▼ button (for Mac OS X 10.6 or 10.5.8) to extend this dialog box.

Printing

3 Select the product you are using as the Printer setting.

Note:
Depending on your application, you may not be able to select some of the items in this dialog box. If so, click **Page Setup** on the File menu of your application, and then make suitable settings.

4 Select the appropriate Paper Size setting.

5 Select the appropriate Orientation setting.

Note:
Select landscape orientation when printing envelopes.

6 Select **Print Settings** from the pop-up menu.

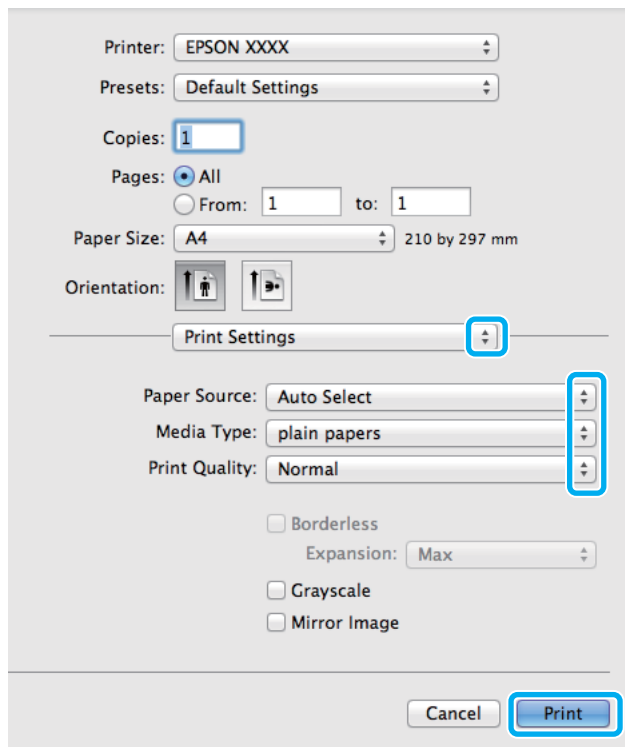

7 Select the appropriate **Paper Source** setting.

8 Select the appropriate Media Type setting.
➔ [“Paper type settings from the printer driver”](#) on page 21

9 Select the appropriate Print Quality setting.

Note:
If you are printing high-density data on plain paper, letterhead, or preprinted paper, select Standard-Vivid to make your printout vivid.

Printing

- 10 Click **Print** to start printing.

Canceling printing

If you need to cancel printing, follow the instructions in the appropriate section below.

Using the product button

Press  to cancel a print job in progress.

For Windows

Note:

You cannot cancel a print job that has been completely sent to the product. In this case, cancel the print job by using the product.

- 1 Access the EPSON Status Monitor 3.
➔ [“For Windows” on page 86](#)
- 2 Click the **Print Queue** button. The Windows Spooler appears.
- 3 Right-click on the job you want to cancel and then select **Cancel**.

For Mac OS X

Follow the steps below to cancel a print job.

Note:

If you have sent a print job from a Mac OS X 10.6 or 10.5.8 through the network, you may not be able to cancel printing from the computer. Press  on the product's control panel to cancel a print job. To solve this problem, see the online Network Guide.

- 1 Click your product icon in the Dock.
- 2 In the Document Name list, select the document which is printing.

Printing

- Click the **Delete** button to cancel the print job.

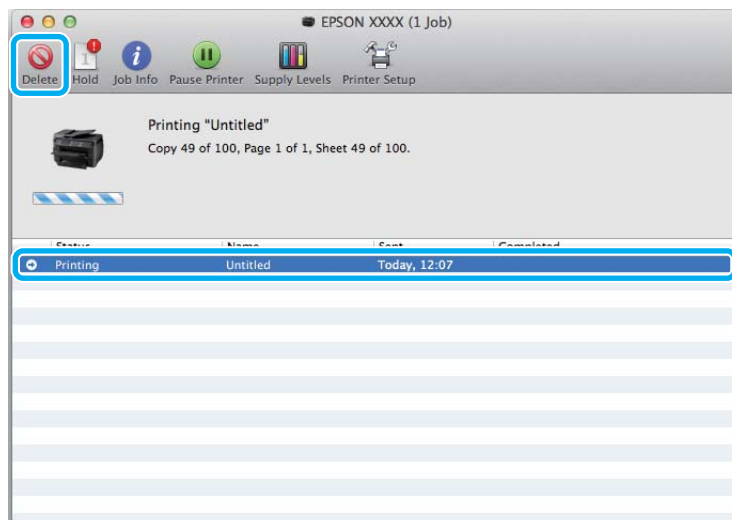

For Mac OS X 10.8:
Click the  button to cancel the print job.

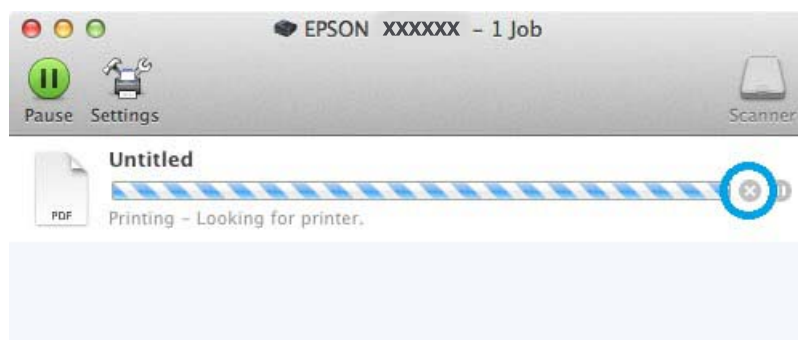

Other Options

Product presets (For Windows Only)

Printer driver presets make printing a snap. You can also create presets of your own.

Product settings for Windows

- Access the printer settings.
➔ [“Accessing the printer driver for Windows” on page 28](#)
- Select a Printing Presets in the Main tab. Product settings are automatically set to the values displayed in the pop-up window.

2-sided printing

Use the printer driver to print on both sides of the paper.

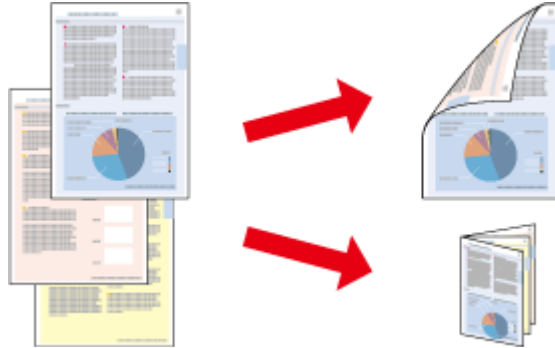

Note:

- This feature may not be available at some settings.
- The loading capacity differs during 2-sided printing.
➔ “Selecting Paper” on page 18
- Only use papers that are suitable for 2-sided printing. Otherwise, the printout quality may deteriorate.
➔ “Selecting Paper” on page 18
- Manual 2-sided printing may not be available when the product is accessed over a network or is used as a shared printer.
- If the ink runs low during automatic 2-sided printing, the product stops printing and the ink needs to be replaced. When ink replacement is complete, the product starts printing again, but there may be some missing parts in your print. If this happens, print again the page that has missing parts.
- Depending on the paper and the amount of ink used to print text and images, ink may bleed through to the other side of the paper.
- The surface of the paper may be smeared during 2-sided printing.

Note for Windows:

- Four types of 2-sided printing are available: automatic standard, automatic folded booklet, manual standard and manual folded booklet.
- Manual 2-sided printing is available only when EPSON Status Monitor 3 is enabled. To enable the status monitor, access the printer driver and click the **Maintenance** tab followed by the **Extended Settings** button. In the Extended Settings window, check the **Enable EPSON Status Monitor 3** check box.
- When automatic 2-sided printing is performed, printing may be slow depending on the combination of options selected for Select Document Type in the Print Density Adjustment window and for Quality in the Main window.

Note for Mac OS X:

- Mac OS X supports automatic standard 2-sided printing only.
- When automatic 2-sided printing is performed, printing may be slow depending on the Document Type setting in Two-sided Printing Settings

Printing

Product settings for Windows

- 1 Access the printer settings.
➔ [“Accessing the printer driver for Windows” on page 28](#)

- 2 Select the appropriate 2-Sided Printing setting.

Note:

Depending on the driver version, the 2-Sided Printing setting may become available when you select the check box. When using automatic printing, make sure the **Auto** check box is checked.

- 3 Click **Settings**, and make the appropriate settings.

Note:

If you want to print a folded booklet, select **Booklet**.

- 4 Check the other settings and print.

Note:

- When printing automatically, and if you are printing high-density data such as photos or graphs, we recommend making the settings in the Print Density Adjustment window.
- The actual binding margin may be different from the specified settings depending on your application. Experiment with a few sheets to examine actual results before printing the entire job.
- Manual 2-sided printing allows you to print the even-numbered pages first. When you print odd-numbered pages, a blank sheet of paper is output at the end of the print job.
- When you are printing manually, make sure that the ink is completely dry before reloading the paper.

Product settings for Mac OS X

- 1 Access the Print dialog box.
➔ [“Accessing the printer driver for Mac OS X” on page 29](#)

- 2 Make the appropriate settings in the Two-sided Printing Settings pane.

- 3 Check the other settings and print.

Note:

If you are printing high-density data such as photos or graphs, we recommend adjusting Print Density and Increased Ink Drying Time settings manually.

Fit to page printing

Lets you automatically enlarge or reduce the size of your document to fit the paper size selected in the printer driver.

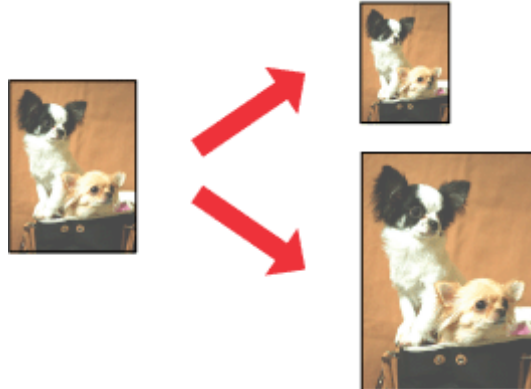
**Note:**

This feature may not be available at some settings.

Product settings for Windows

- 1 Access the printer settings.
➔ [“Accessing the printer driver for Windows” on page 28](#)
- 2 Select **Reduce/Enlarge Document** and **Fit to Page** in the More Options tab, and then select the size of the paper you are using from Output Paper.

Note:

*If you want to print a reduced image with centering, select **Center**.*

- 3 Check the other settings and print.

Product settings for Mac OS X

- 1 Access the Print dialog box.
➔ [“Accessing the printer driver for Mac OS X” on page 29](#)
- 2 Choose **Scale to fit paper size** for Destination Paper Size in the Paper Handling pane and select the desired paper size from the pop-up menu.
- 3 Check the other settings and print.

Pages per Sheet printing

Lets you use the printer driver to print two or four pages on a single sheet of paper.

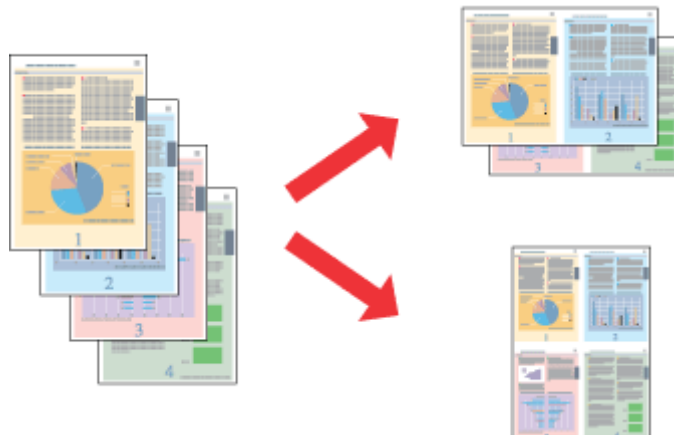
**Note:**

This feature may not be available at some settings.

Product settings for Windows

- 1 Access the printer settings.
➔ [“Accessing the printer driver for Windows” on page 28](#)
- 2 Select **2-Up** or **4-Up** as Multi-Page in the Main tab.
- 3 Click **Page Order**, and make the appropriate settings.
- 4 Check the other settings and print.

Product settings for Mac OS X

- 1 Access the Print dialog box.
➔ [“Accessing the printer driver for Mac OS X” on page 29](#)
- 2 Select the desired number of Pages per Sheet and the Layout Direction (page order) in the Layout pane.
- 3 Check the other settings and print.

Anti-Copy Pattern printing (for Windows Only)

This function allows you to print a document as a copy-protected document. When you try to copy a copy-protected document, the string that you added as the anti-copy pattern is printed several times on the document.

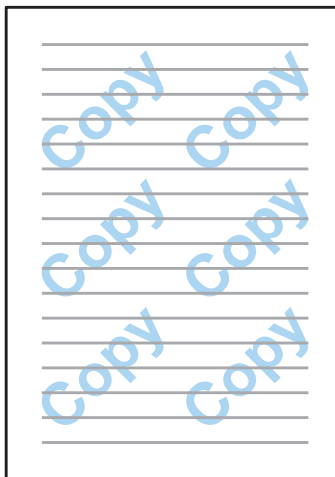
**Note:**

This feature may not be available at some settings.

1 Access the printer settings.
➔ [“Accessing the printer driver for Windows” on page 28](#)

2 Click **Watermark Features** on the More Options tab, and then select an Anti-Copy Pattern from the Anti-Copy Pattern list.

Note:

This feature is available only with the following settings selected.

Paper Type: plain papers

Quality: Standard

Auto 2-Sided Printing: Off

Color Correction: Automatic

*If you want to create your own watermark, click **Add/Delete**. For more details about each setting, see the online help.*

3 Click **Settings**, and make the appropriate settings.

Note:

Anti-Copy Pattern are printed in monochrome only.

4 Click **OK** to return to the More Options window.

5 Click **OK** to close the printer settings window and print.

Watermark printing (For Windows Only)

This function allows you to print a text-based or image-based watermark on your document.

**Note:**

This feature may not be available at some settings.

- 1** Access the printer settings.
➔ [“Accessing the printer driver for Windows” on page 28](#)
- 2** Click **Watermark Features** on the More Options tab, and then select a watermark from the Watermark list.

Note:

- If you want to create your own watermark, click **Add/Delete**. For more details about each setting, see the online help.*
- Saved watermarks can only be used with the printer driver in which you saved the settings. Even if multiple printer names are set for a printer driver, the settings are only available for the printer name in which you saved the settings.*
- When sharing the printer on a network, you cannot create a user defined watermark as a client.*

- 3** Click **Settings**, and then make the appropriate settings.
- 4** Click **OK** to return to the More Options window.
- 5** Click **OK** to close the printer settings window and print.

Header/Footer printing (For Windows Only)

This function allows you to print user name, computer name, date, time, or collate number, at the top or bottom of each page in a document.



- 1 Access the printer settings.
➔ [“Accessing the printer driver for Windows” on page 28](#)
- 2 Click **Watermark Features** on the More Options tab, select **Header/Footer**, and then click **Settings**.
- 3 Select the necessary items from the drop-down list in the Header Footer Settings window.

Note:
If you select Collate Number, the number of copies is printed.

- 4 Click **OK** to return to the More Options window.
- 5 Click **OK** to close the printer settings window and print.

Printing Confidential Jobs

This function is only available for the WF-5190 Series.

This function allows you to set a password when sending a job. When a password is set, the job cannot be printed until the password is entered on the product's control panel.

- 1 Access the printer settings.
➔ [“Accessing the printer driver for Windows” on page 28](#)
- 2 Select Confidential Job on the More Options tab.
- 3 Make settings such as the password, user name, and job name on the Confidential Job Settings screen, and then click **OK**.

Printing

- 4 Make the necessary settings.
- 5 Click OK to close the printer settings screen and send the print job.
- 6 Go to the printer, and access **Menu > Confidential Job** from the Home screen.
- 7 Enter your user name and select the job you sent.
- 8 Enter the password you set, and then press the **OK** button to start printing.

Administrator Settings for Printer Driver (for Windows Only)

Administrators can lock the following printer driver settings for each user to prevent unintended changes of the settings.

- Anti-Copy Pattern
- Watermark
- Header/Footer
- Color
- 2-sided printing
- Multi-Page

Note:

You need to logon as an administrator in Windows.

- 1 Windows 8 and Server 2012:
Select **Desktop, Settings, charm, Control Panel**, and then select **Devices and Printers** from the Hardware and Sound category.

Windows 7 and Server 2008 R2:

Click the start button, and then select **Devices and Printers**.

Windows Vista and Server 2008:

Click the start button, select **Control Panel**, and then select **Printer** from the Hardware and Sound category.

Windows XP and Server 2003:

Click **Start**, select **Control Panel**, and then select **Printers and Faxes** from the Printers and Other Hardware category.

Printing

- 2 Windows 8, 7, Server 2008, and Server 2012:
Right-click on the product, or press and hold the product, select **Printer properties**, **Optional Settings**, and then select the **Driver Settings** button.

Windows Vista and Server 2008:

Right-click the icon for your product, click **Optional Settings**, and then click the **Driver Settings** button.

Windows XP and Server 2003:

Right-click the icon for your product, click **Optional Settings**, and then click the **Driver Settings** button.

- 3 Make the appropriate settings. For more details about each setting, see the online help.

- 4 Click **OK**.

Using the PostScript Printer Driver

See the following for details on installing the PostScript printer driver.

➔ [“Installing the PostScript Printer Driver” on page 77](#)

Using the Epson Universal Printer Driver

See the following for details on installing the Epson universal printer driver.

➔ [“Installing the Epson Universal Printer Driver \(for Windows Only\)” on page 80](#)

Note:

Whenever possible select fonts in your application. See your software documentation for instructions. If you are sending unformatted text to the printer directly from DOS or if you are using a simple software package that does not include font selection, you can select fonts using the printer's control panel menus.

Menu List of Control Panel

Menu List of Control Panel

The table below shows the functions and settings available from the Menu on the control panel. See the following section for details on the Wi-Fi Setup displayed on the Home screen.

➔ [“System Administration Settings” on page 46](#)

Menu	Settings Description		
Ink Levels	Checks the status of ink cartridges and the maintenance box.		
Maintenance	Print Head Nozzle Check	Prints a pattern to check if the print head nozzles are clogged.	
	Print Head Cleaning	Cleans the print head to clear clogged nozzles.	
	Print Head Alignment	Ruled Line Alignment	Corrects vertical ruled lines that are not straight.
		Vertical Alignment	Corrects vertical gaps in a printout.
		Horizontal Alignment	Corrects horizontal gaps in a printout.
	Thick Paper	Select On when printing on thick paper to avoid smearing.	
Paper Guide Cleaning	Perform this function to clean the inside of the product.		
Paper Setup	Select the paper size and paper type you loaded in each paper source. This menu is displayed each time you load paper in the paper cassette.		
Print Status Sheet	Configuration Status Sheet	Prints a sheet showing the current printer settings.	
	Supply Status Sheet	Prints a sheet showing information about consumables.	
	Usage History Sheet	Prints a sheet showing the history of the printer's usage.	
	PS3 Status Sheet*	Prints a sheet showing the current PS3 status.	
	PS3 Font List*	Prints a sheet showing the PS3 font list available for the product.	
	PCL Font List*	Prints a sheet showing the PCL font list available for the product.	
Network Status	You can see the current network settings and print a network status sheet.		
Confidential Job*	Displays a list of jobs for which passwords have been set. To print the job, select the job and enter the password. ➔ “Printing Confidential Jobs” on page 42		
Admin Settings	Admin Password	You can change or reset the password which is specified in Lock Setting.	
	Lock Setting	Select On to lock the control panel to prevent unintended changes made by using the control panel.	
System Administration	➔ “System Administration Settings” on page 46		

* This function is only supported by the WF-5190 Series.

Menu List of Control Panel

System Administration Settings

The administrator can lock the control panel to prevent unintended changes from being made. To lock the control panel, select the menus as shown below, then enter the password.

Menu > Admin Settings > Lock Settings > On

The password is required when entering the System Administration settings in Menu. The password set in Lock Settings is also necessary when making settings in Epson WebConfig or EpsonNet Config.

Note:

If you forget your password, contact your dealer.

Menu	Settings and Description			
Printer Settings	Paper Source Settings	Rear Paper Feed Priority		Select Normal to give priority to the rear paper feed.
		A4/Letter Auto Switching		Make the paper settings for A4 and Letter. When A4 or Letter size paper is selected for printing and there is no paper source set for the selected paper size, the printout is output using an alternate paper size (Letter for A4, or A4 for Letter).
		Auto Select Settings		Select On to feed from the paper source containing paper that matches your Paper Source Settings.
		Error Notice	Paper Size Notice	Select On to display an error message when the paper size and type settings made for each paper source and the print settings made in each mode do not match.
	Paper Type Notice			
	USB I/F Timeout Setting*	Specify the length of time in seconds that must elapse before ending USB communication with a computer after the printer receives a print job from the computer. In PS3/PCL printing, the end of a job is sometimes not clearly defined which causes endless USB communication. When this occurs, the printer ends communication after the specified time has elapsed. Enter 0 (zero) to disable the timeout feature.		
	Printing Language*	Set the printing language for the USB interface and Network interface.		
	Auto Error Solver	Select an action when a 2-sided printing error occurs due to a lack of available paper for 2-sided printing, or when a memory full error occurs while the printer is processing a print job. Select On to display a warning and print on one side of paper only (for a 2-sided printing error), or to print only the part of the data that the printer could process.		
PC Connection via USB	Select whether to enable or disable the USB interface. If Disable is selected, the computer does not recognize the product even if it is connected using a USB cable.			

Menu List of Control Panel

Menu	Settings and Description		
Common Settings	Sleep Timer	Specify the length of the time until the LCD panel turns black.	
	Power Off Timer	Specify the length of the time until the power turns off automatically. You can adjust the time before power management is applied. Any increase will affect the product's energy efficiency. Please consider the environment before making any change.	
	LCD Contrast	Adjusts the brightness of the LCD panel.	
	Date/Time Settings	Date/Time	Enter the current date and time.
		Daylight Saving Time	Select On to set summer time.
		Time Difference	Enter the time difference between UTC and the current time zone.
	Language	Select the display language.	
Scroll Speed	Select the scroll speed of the LCD screen.		
Wi-Fi/Network Settings	Wi-Fi/Network Status		You can see the current network settings and print a networks status sheet.
	Wi-Fi Setup	Wi-Fi Setup Wizard	For details on the setting items, see the online Network Guide.
		Push Button Setup (WPS)	
		PIN Code Setup (WPS)	
		Wi-Fi Auto Connect	
		Disable Wi-Fi	Network problems may be resolved by disabling or initializing the Wi-Fi settings, and then making the settings again. For details, see the online Network Guide.
	Wi-Fi Direct Setup	For details on the setting items, see the online Network Guide.	
	Connection Check		You can check the network connection status, and print the report. If there is any problem with the connection, the report helps you find the solution.
Advanced Setup		For details on the setting items, see the online Network Guide.	
Epson Connect Services	For instructions on use, see the Epson Connect guide. ➔ "Using Epson Connect Service" on page 10		
Google Cloud Print Services			

Menu List of Control Panel

Menu	Settings and Description		
Universal Print Settings	Top Offset	Adjusts the top or left margin of the page.	
	Left Offset		
	Top Offset in Back	Adjusts the top or left margin of the backside of the page when printing on both sides.	
	Left Offset in Back		
	Check Paper Width	Select On to check paper width before printing. This prevents printing beyond the edges of the paper when the paper size settings is wrong, but may reduce the printing speed.	
	Dry Time	Select the drying time when printing on both sides.	
	Skip Blank Page	Select On to skip blank pages automatically.	
PDL Print Configuration *	Common Settings	Paper Size	Select the paper size.
		Paper Type	Select the paper type.
		Orientation	Select the orientation of your print.
		Quality	Select the print quality.
		Ink Save Mode	Select On to save ink.
		Print Order	Select Last Page on Top to print from the last page of a document. Select First Page on Top to print from the first page of a document.
		Number of Copies	Set the number of copies.
		Binding Margin	Select the binding margin.
		Auto Paper Ejection	Select On to eject paper automatically when the receiving time has elapsed.
		2-Sided Printing	Select On to perform double-sided printing.

Menu List of Control Panel

Menu	Settings and Description											
		PCL Menu	<table border="1"> <tr> <td data-bbox="842 282 1018 338">Font Source</td> <td data-bbox="1018 282 1439 338">Select the default font source.</td> </tr> <tr> <td data-bbox="842 338 1018 483">Font Number</td> <td data-bbox="1018 338 1439 483">Select the default font number for the default font source. The available number depends on the settings you made.</td> </tr> <tr> <td data-bbox="842 483 1018 685">Pitch</td> <td data-bbox="1018 483 1439 685">Set the default font pitch if the font is scalable and of fixed-pitch. You can select from 0.44 to 99.99 cpi (characters per inch), in 0.01-cpi increments. This item may not appear depending on the Font Source or Font Number settings.</td> </tr> <tr> <td data-bbox="842 685 1018 918">Height</td> <td data-bbox="1018 685 1439 918">Set the default font height if the font is scalable and proportional. You can select from 4.00 to 999.75 points, in 0.25-point increments. This item may not appear depending on the Font Source or Font Number settings.</td> </tr> </table>	Font Source	Select the default font source.	Font Number	Select the default font number for the default font source. The available number depends on the settings you made.	Pitch	Set the default font pitch if the font is scalable and of fixed-pitch. You can select from 0.44 to 99.99 cpi (characters per inch), in 0.01-cpi increments. This item may not appear depending on the Font Source or Font Number settings.	Height	Set the default font height if the font is scalable and proportional. You can select from 4.00 to 999.75 points, in 0.25-point increments. This item may not appear depending on the Font Source or Font Number settings.	
Font Source	Select the default font source.											
Font Number	Select the default font number for the default font source. The available number depends on the settings you made.											
Pitch	Set the default font pitch if the font is scalable and of fixed-pitch. You can select from 0.44 to 99.99 cpi (characters per inch), in 0.01-cpi increments. This item may not appear depending on the Font Source or Font Number settings.											
Height	Set the default font height if the font is scalable and proportional. You can select from 4.00 to 999.75 points, in 0.25-point increments. This item may not appear depending on the Font Source or Font Number settings.											
			<table border="1"> <tr> <td data-bbox="842 918 1018 1151">Symbol Set</td> <td data-bbox="1018 918 1439 1151">Set the default symbol set. If the font you selected in Font Source and Font Number is not available in the new Symbol Set setting, the Font Source and the Font Number settings are automatically replaced with the default value, IBM-US.</td> </tr> <tr> <td data-bbox="842 1151 1018 1413">Form</td> <td data-bbox="1018 1151 1439 1413">Set the number of lines for the selected paper size and orientation. This also causes a line spacing (VMI) change, and the new VMI value is stored in the printer. This means that later changes in the Page Size or Orientation settings cause changes in the Form value, based on the stored VMI.</td> </tr> <tr> <td data-bbox="842 1413 1018 1525">CR Function</td> <td data-bbox="1018 1413 1439 1525" rowspan="2">Set for using particular operating systems, such as UNIX.</td> </tr> <tr> <td data-bbox="842 1525 1018 1525">LF Function</td> </tr> <tr> <td data-bbox="842 1525 1018 1814">Paper Source Assign</td> <td data-bbox="1018 1525 1439 1814">Set the assignment for the paper source select command. When 4 is selected, the commands are set as compatible with the HP LaserJet 4. When 4K is selected, the commands are set as compatible with the HP LaserJet 4000, 5000, and 8000. When 5S is selected, the commands are set as compatible with the HP LaserJet 5S.</td> </tr> </table>	Symbol Set	Set the default symbol set. If the font you selected in Font Source and Font Number is not available in the new Symbol Set setting, the Font Source and the Font Number settings are automatically replaced with the default value, IBM-US.	Form	Set the number of lines for the selected paper size and orientation. This also causes a line spacing (VMI) change, and the new VMI value is stored in the printer. This means that later changes in the Page Size or Orientation settings cause changes in the Form value, based on the stored VMI.	CR Function	Set for using particular operating systems, such as UNIX.	LF Function	Paper Source Assign	Set the assignment for the paper source select command. When 4 is selected, the commands are set as compatible with the HP LaserJet 4. When 4K is selected, the commands are set as compatible with the HP LaserJet 4000, 5000, and 8000. When 5S is selected, the commands are set as compatible with the HP LaserJet 5S.
Symbol Set	Set the default symbol set. If the font you selected in Font Source and Font Number is not available in the new Symbol Set setting, the Font Source and the Font Number settings are automatically replaced with the default value, IBM-US.											
Form	Set the number of lines for the selected paper size and orientation. This also causes a line spacing (VMI) change, and the new VMI value is stored in the printer. This means that later changes in the Page Size or Orientation settings cause changes in the Form value, based on the stored VMI.											
CR Function	Set for using particular operating systems, such as UNIX.											
LF Function												
Paper Source Assign	Set the assignment for the paper source select command. When 4 is selected, the commands are set as compatible with the HP LaserJet 4. When 4K is selected, the commands are set as compatible with the HP LaserJet 4000, 5000, and 8000. When 5S is selected, the commands are set as compatible with the HP LaserJet 5S.											

Menu List of Control Panel

Menu	Settings and Description														
		PS3 Menu	<table border="1"> <tr> <td data-bbox="850 282 1018 427">Error Sheet</td> <td data-bbox="1018 282 1442 427">Select On to print out an error sheet when an error occurs in the PS3 mode or when the PDF file you tried to print is not a supported version.</td> </tr> <tr> <td data-bbox="850 427 1018 483">Coloration</td> <td data-bbox="1018 427 1442 483">Select the coloration.</td> </tr> <tr> <td data-bbox="850 483 1018 629">Image Protect</td> <td data-bbox="1018 483 1442 629">Select On if you do not want the print quality to be reduced. In this case printing will be stopped when memory is insufficient.</td> </tr> <tr> <td data-bbox="850 629 1018 891">Binary</td> <td data-bbox="1018 629 1442 891">Select On for Binary data and select Off for ASCII data. Binary can only be used with network connection. To use the Binary data, make sure your application supports Binary data and that SEND CTRL-D Before Each Job and SEND CTRL-D After Each Job are set to No.</td> </tr> <tr> <td data-bbox="850 891 1018 1037">Text Detection</td> <td data-bbox="1018 891 1442 1037">Select On if you want text file converted to a PostScript file when printing. This setting is available only when PS3 is selected in Printing Language.</td> </tr> <tr> <td data-bbox="850 1037 1018 1240">PDF Page Size</td> <td data-bbox="1018 1037 1442 1240">Set the paper size when you send the PDF file directory from a computer or some other device. When Auto is selected, the paper size is determined based on the size of the first pager that is printed.</td> </tr> </table>	Error Sheet	Select On to print out an error sheet when an error occurs in the PS3 mode or when the PDF file you tried to print is not a supported version.	Coloration	Select the coloration.	Image Protect	Select On if you do not want the print quality to be reduced. In this case printing will be stopped when memory is insufficient.	Binary	Select On for Binary data and select Off for ASCII data. Binary can only be used with network connection. To use the Binary data, make sure your application supports Binary data and that SEND CTRL-D Before Each Job and SEND CTRL-D After Each Job are set to No .	Text Detection	Select On if you want text file converted to a PostScript file when printing. This setting is available only when PS3 is selected in Printing Language.	PDF Page Size	Set the paper size when you send the PDF file directory from a computer or some other device. When Auto is selected, the paper size is determined based on the size of the first pager that is printed.
Error Sheet	Select On to print out an error sheet when an error occurs in the PS3 mode or when the PDF file you tried to print is not a supported version.														
Coloration	Select the coloration.														
Image Protect	Select On if you do not want the print quality to be reduced. In this case printing will be stopped when memory is insufficient.														
Binary	Select On for Binary data and select Off for ASCII data. Binary can only be used with network connection. To use the Binary data, make sure your application supports Binary data and that SEND CTRL-D Before Each Job and SEND CTRL-D After Each Job are set to No .														
Text Detection	Select On if you want text file converted to a PostScript file when printing. This setting is available only when PS3 is selected in Printing Language.														
PDF Page Size	Set the paper size when you send the PDF file directory from a computer or some other device. When Auto is selected, the paper size is determined based on the size of the first pager that is printed.														
Security Settings*	Delete All Confidential Jobs	Select to delete all confidential jobs stored in the printer.													
Eco Mode	You can adjust the time before power management is applied. Any increase will affect the product's energy efficiency. Please consider the environment before making any change. Select On to enable all the following Eco Mode functions.														
	Sleep Timer	Specify the length of the time until the LCD panel turns black.													
	Power Off Timer	Specify the length of the time until the power turns off automatically.													
Clear Internal Memory Data*	Clears the selected memory data.														
Restore Default Settings	Resets the selected settings to their defaults.														

* This function is only supported by the WF-5190 Series.

Ink Cartridge and Consumable Information

Ink Cartridges

Product	Icon	Black	Cyan	Magenta	Yellow
WF-5110* WF-5190*	Tower of Pisa 	79/79XL/T7891	79/79XL/T7892	79/79XL/T7893	79/79XL/T7894
WF-5111 WF-5191	-	T7921	T7922	T7923	T7924

* For users in Europe, visit the following website for information on Epson's ink supply unit yields.
<http://www.epson.eu/pageyield>

For Australia / New Zealand

Product	Black	Cyan	Magenta	Yellow
WF-5190	786 786XL 788XXL	786 786XL 788XXL	786 786XL 788XXL	786 786XL 788XXL

Note:

Not all cartridges are available in all regions.

Color	Black, Cyan, Magenta, Yellow
Cartridge life	For best results, use up ink cartridge within six months of opening the package.
Temperature	Storage: -20 to 40 °C (-4 to 104 °F) 1 month at 40 °C (104 °F) Freezing: -10 °C (14 °F)

* Ink thaws and is usable after approximately 3 hours at 25 °C (77 °F).

Maintenance Box

You can use the following maintenance box with this product.

	Part number
Maintenance Box	T6710

Replacing Ink Cartridges

Ink Cartridge Safety Instructions, Precautions, and Specifications

Safety instructions

Observe the following when handling the ink cartridges:

- Keep ink cartridges out of the reach of children.
- Be careful when you handle used ink cartridges, as there may be some ink around the ink supply port.
 - If ink gets on your skin, wash the area thoroughly with soap and water.
 - If ink gets into your eyes, flush them immediately with water. If discomfort or vision problems continue after a thorough flushing, see a doctor immediately.
 - If ink gets into your mouth, spit it out immediately and see a doctor right away.
- Before installing the new ink cartridge in the printer, shake it back and forth horizontally in 10 centimeter movements about 15 times within five seconds.
- Use the ink cartridge before the date printed on its package.
- Use up the ink cartridge within six months of installation for best results.
- Do not disassemble or remodel the ink cartridge, otherwise you may not be able to print normally.
- Do not touch the green chip on the side of the cartridge. Doing so may prevent normal operation and printing.
- The chip on this ink cartridge retains a variety of cartridge-related information, such as the ink cartridge status, so that the cartridge may be removed and reinserted freely.
- If you remove an ink cartridge for later use, protect the ink supply area from dirt and dust, and store it in the same environment as this product. Note that there is a valve in the ink supply port, making covers or plugs unnecessary, but care is needed to prevent the ink from staining items that the cartridge touches. Do not touch the ink supply port or surrounding area.

Precautions on ink cartridge replacement

Read all of the instructions in this section before replacing the ink cartridges.

- For the best printing results, use up the ink cartridge within six months of installation.
- If you move ink cartridges from a cold place to a warm place, leave it at room temperature for more than three hours before using the ink cartridge.
- Do not drop or knock it against hard objects; otherwise, the ink may leak.

Replacing Ink Cartridges

- ❑ Do not move the print head by hand; otherwise, you may damage the printer.
- ❑ This printer uses ink cartridges equipped with a green chip that monitors the amount of ink used by each cartridge. Cartridges are usable even if they are removed and reinserted.
- ❑ If you need to remove an ink cartridge temporarily, be sure to protect the ink supply area from dirt and dust. Store the ink cartridge in the same environment as the printer.
- ❑ Never turn off the printer during initial ink charging. The ink may fail to filled up and the printer may become unavailable to print.
- ❑ The ink supply port is equipped with a valve designed to contain the release of excess ink; there is no need to supply your own covers or plugs. However, careful handling is recommended. Do not touch the supply port of the ink cartridge or its surrounding area.
- ❑ Other products not manufactured by Epson may cause damage that is not covered by Epson's warranties, and under certain circumstances, may cause erratic printer behavior.
- ❑ Epson recommends the use of genuine Epson ink cartridges. Epson cannot guarantee the quality or reliability of non-genuine ink. The use of non-genuine ink may cause damage that is not covered by Epson's warranties, and under certain circumstances, may cause erratic printer behavior. Information about non-genuine ink levels may not be displayed.
- ❑ Leave the old cartridge installed in the printer until you have obtained a replacement; otherwise, ink remaining in the print head nozzles may dry out.
- ❑ When color ink is expended and black ink still remains, you can continue printing temporarily with black ink only.
 - ➔ ["Temporary Printing with Black Ink When Color Ink Cartridges are Expended" on page 57](#)
- ❑ Never turn off the printer while replacing the ink cartridge. Doing so may damage the green chip on the ink cartridge and the printer may not print properly.
- ❑ You cannot use the cartridges that came with your product for the replacement.

Ink Cartridge Specifications

- ❑ Epson recommends using the ink cartridge before the date printed on the package.
- ❑ The ink cartridges packaged with your product are partly used during initial setup. In order to produce high quality printouts, the print head in your product will be fully charged with ink. This one-off process consumes a quantity of ink and therefore these cartridges may print fewer pages compared to subsequent ink cartridges.
- ❑ Quoted yields may vary depending on the images that you are printing, the paper type that you are using, the frequency of your prints and environmental conditions such as temperature.
- ❑ To ensure you receive premium print quality and to help protect your print head, a variable ink safety reserve remains in the cartridge when your product indicates to replace the cartridge. The yields quoted for you do not include this reserve.
- ❑ Although the ink cartridges may contain recycled materials, this does not affect product function or performance.
- ❑ When printing in monochrome or grayscale, color inks instead of black ink may be used depending on the paper type or print quality settings. This is because a mixture of color inks is used to create black.

Checking the Ink Cartridge Status

For Windows

Note:

When an ink cartridge is running low, the Low Ink Reminder screen automatically appears. You can also check the ink cartridge status from this screen. If you do not want to display this screen, first access the printer driver and then click the **Maintenance** tab, and then **Monitoring Preferences**. On the Monitoring Preferences screen, clear the **See Low Ink Reminder alerts** check box.

To check the ink cartridge status, do one of the following:

- Open the printer driver, click the **Main** tab, and then click the **Ink Levels** button.
- Double-click the product shortcut icon on your Windows taskbar. To add a shortcut icon to the taskbar, see the following section:
 - ➔ [“From the shortcut icon on the taskbar” on page 29](#)

Replacing Ink Cartridges

- ❑ Open the printer driver, click the **Maintenance** tab, then click the **EPSON Status Monitor 3** button. A graphic displays the ink cartridge status.

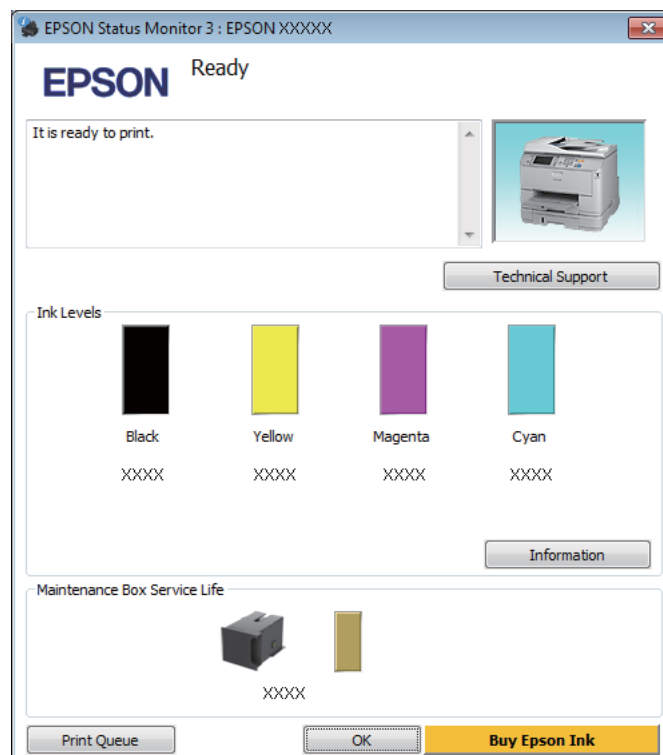

Note:

- ❑ If EPSON Status Monitor 3 does not appear, access the printer driver and click the **Maintenance** tab and then the **Extended Settings** button. In the Extended Settings window, check the **Enable EPSON Status Monitor 3** check box.
- ❑ Depending on current settings, the simplified status monitor may be displayed. Click the **Details** button to display the window above.
- ❑ The ink levels displayed are an approximate indication.

For Mac OS X

You can check the ink cartridge status using EPSON Status Monitor. Follow the steps below.

- 1 Access the Epson Printer Utility 4.
➔ [“Accessing the printer driver for Mac OS X” on page 29](#)

Replacing Ink Cartridges

- 2 Click the **EPSON Status Monitor** icon. The EPSON Status Monitor appears.



Note:

- The graphic displays the ink cartridge status when EPSON Status Monitor was first opened. To update the ink cartridge status, click **Update**.
- The ink levels displayed are an approximate indication.

Using the control panel

- 1 Enter **Menu** from the Home screen.
- 2 Select **Ink Levels**.

Note:

- The ink levels displayed are an approximate indication.
- The status icon on the right of the LCD screen indicates the status of the maintenance box.

Temporary Printing with Black Ink When Color Ink Cartridges are Expended

When color ink is expended and black ink still remains, you can continue printing for a short time using only black ink. However, you should replace the expended ink cartridge(s) as soon as possible. See the following section to continue printing temporarily with black ink.

Note:

The actual amount of time will vary depending on the usage conditions, images printed, print settings, and frequency of use.

For Windows

Note for Windows:

*This function is available only when EPSON Status Monitor 3 is enabled. To enable the status monitor, access the printer driver and click the **Maintenance** tab followed by the **Extended Settings** button. In the Extended Settings window, check the **Enable EPSON Status Monitor 3** check box.*

Follow the steps below to continue printing temporarily with black ink.

Replacing Ink Cartridges

- 1 When EPSON Status Monitor 3 tells you to cancel your print job, click **Cancel** or **Cancel Print** to cancel your print job.

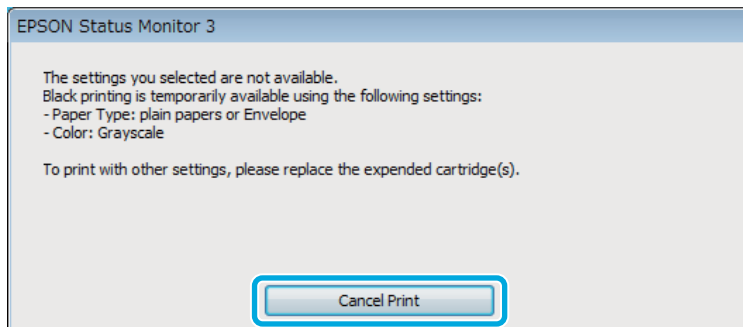
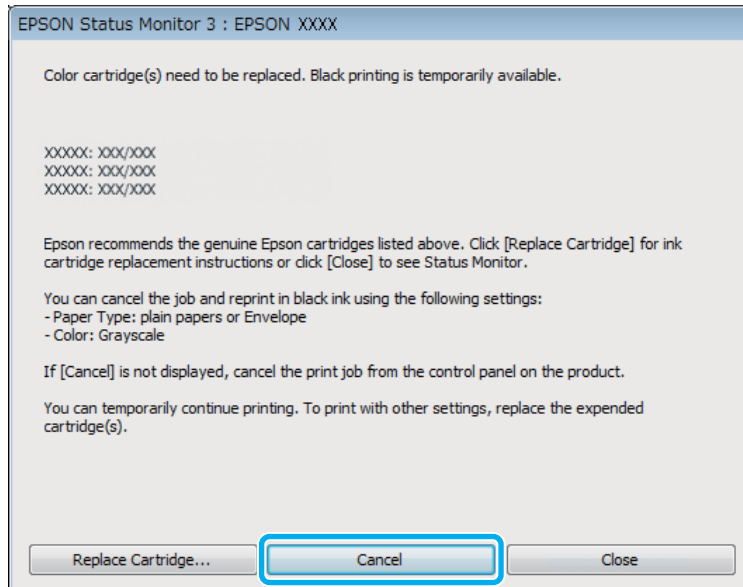

Note:
If the error stating that a color ink cartridge is expended originates with another computer on the network, you may need to cancel the print job at the product.

- 2 Load plain paper or envelope.
- 3 Access the printer settings.
 ➔ [“Accessing the printer driver for Windows” on page 28](#)
- 4 Click the Main tab, and make suitable settings.
- 5 Select **plain papers** or **Envelope** as the Paper Type setting.
- 6 Select the **Grayscale** as the Color setting.
- 7 Click **OK** to close the printer settings window.

Replacing Ink Cartridges

- 8 Print your file.
- 9 EPSON Status Monitor 3 is displayed on your computer screen again. Click **Print in Black** to print with black ink.

For Mac OS X

Follow the steps below to continue printing temporarily with black ink.

- 1 If printing can not be resumed, click the product icon in the Dock. If an error message is displayed prompting you to cancel the print job, click **Delete** and follow the steps below to reprint the document with black ink.

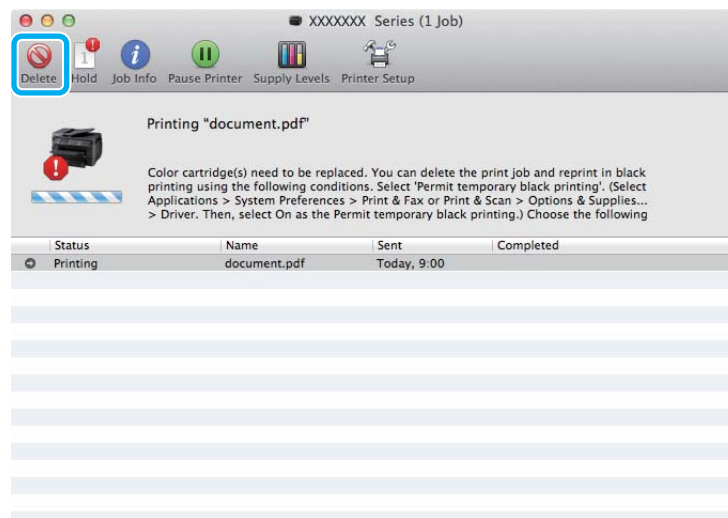

Note:

If the error stating that a color ink cartridge is expended originates with another computer on the network, you may need to cancel the print job at the product.

For Mac OS X 10.8:

Click the  button, and if an error message appears, click **OK**. Follow the steps below to reprint the document with black ink.



Replacing Ink Cartridges

- 2 Open **System Preferences**, click **Print & Scan** (Mac OS X 10.8 or 10.7) or **Print & Fax** (Mac OS X 10.6 or 10.5), and select the product from the Printers list. Next, click **Options & Supplies** and then **Driver**.
- 3 Select **On** for Permit temporary black printing.
- 4 Load plain paper or envelope.
- 5 Access the Print dialog box.
➔ [“Accessing the printer driver for Mac OS X” on page 29](#)
- 6 Click the **Show Details** button (for Mac OS X 10.7) or the ▼ button (for Mac OS X 10.6 or 10.5) to extend this dialog box.
- 7 Select the product you are using as the Printer setting, and then make suitable settings.
- 8 Select **Print Settings** from the pop-up menu.
- 9 Select **plain papers** or **Envelope** as the Media Type setting.
- 10 Select the **Grayscale** check box.
- 11 Click **Print** to close the Print dialog box.

Conserving Black Ink When the Cartridge Is Low (For Windows Only)

Note for Windows:

*This function is available only when EPSON Status Monitor 3 is enabled. To enable the status monitor, access the printer driver and click the **Maintenance** tab followed by the **Extended Settings** button. In the Extended Settings window, check the **Enable EPSON Status Monitor 3** check box.*

Replacing Ink Cartridges

The window below appears when black ink runs low and there is more color ink than black ink. It appears only when **plain papers** is selected as the paper type, and **Standard** is selected as the Quality.

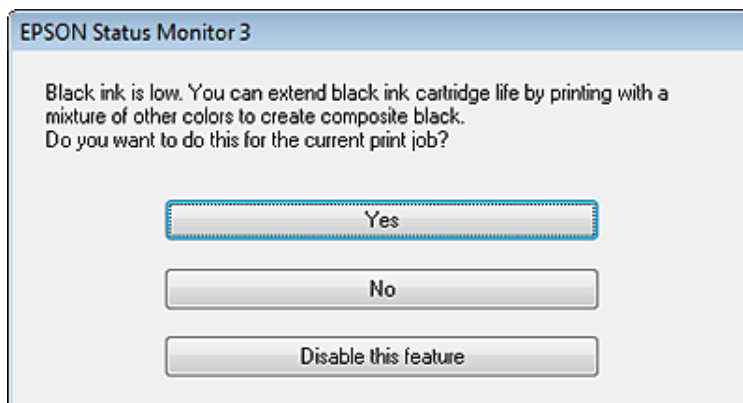

The window gives you the option to either continue using black ink normally or conserve black ink by using a mixture of color inks to create black.

- Click the **Yes** button to use a mixture of color inks to create black. You will see the same window the next time you print a similar job.
- Click the **No** button to continue using the remaining black ink for the job you are printing. You will see the same window the next time you print a similar job, and again have the option to conserve black ink.
- Click **Disable this feature** to continue using the remaining black ink.

Replacing an ink cartridge

When ink cartridges become low or expended, a message appears on your computer or the control panel. You can replace cartridges at any time as long as the product is not operating.

- 1** Open the front cover.

Replacing Ink Cartridges

- 2** Push the ink cartridge that you want to replace and then grip the handle of the cartridge to pull it out of the printer. Dispose of the used cartridge properly. Do not take the used cartridge apart or try to refill it.

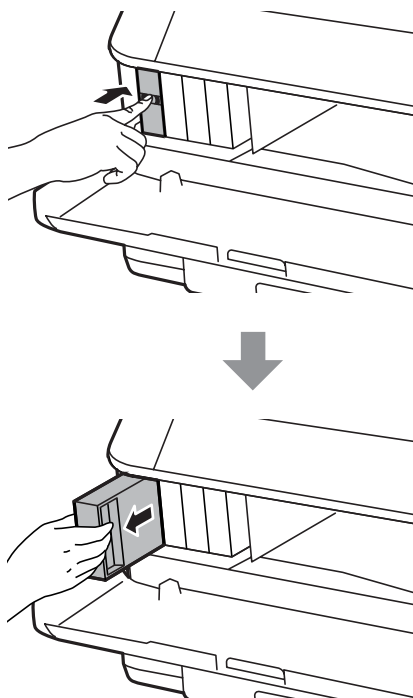

Note:

- ❑ The illustration shows replacement of the black ink cartridge. Replace the cartridge appropriate to your situation.
- ❑ Removed ink cartridges may have ink around the ink supply port, so be careful not to get any ink on the surrounding area when removing the cartridges.

- 3** Remove the replacement ink cartridge from its package. Do not touch the green chip on the side of the cartridge. Doing so may prevent normal operation and printing.

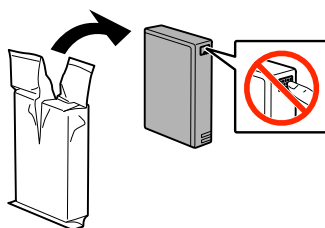

Note:

Do not shake used ink cartridges, as they may leak.

Replacing Ink Cartridges

- 4** Shake the ink cartridge for 5 seconds 15 times horizontally in approximately 10 cm movements as shown in the following illustration.

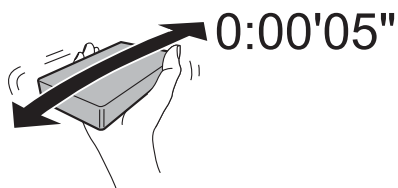

- 5** Place the ink cartridge into the cartridge holder. Push the cartridge until it clicks into place.

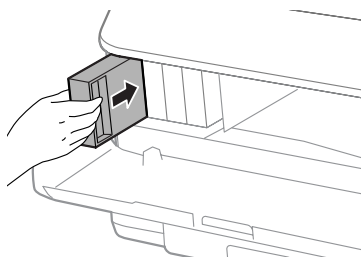

Note:

*If Cartridge Check is displayed on the LCD screen, press the **OK** button to check if the cartridges are installed correctly.*

- 6** Close the front cover.

Note:

Do not turn off the product while the power light is flashing.

Ink cartridge replacement is complete. The printer will return to its previous status.

Maintaining Your Product and Software

Installing Option

Paper Cassette Unit

Installing the paper cassette unit

Follow the steps below to install the paper cassette unit.

Note:

This unit is option.

➔ *“Option” on page 108*

1

Turn the product off and unplug the power cord and all the interface cables.



Caution:

Make sure to unplug the power cord from the product to prevent getting an electric shock.

2

Carefully remove the paper cassette unit from its carton and place it where you intend to set up the product.

Note:

Remove the protective materials from the unit.

Keep all protective materials in case you want to ship the optional paper cassette unit in the future.

3

Align the corners of the product and the unit, then lower the product gently onto the unit so that the connector and two pins on the top of the unit fit into the terminal and the holes on the bottom of the product respectively.

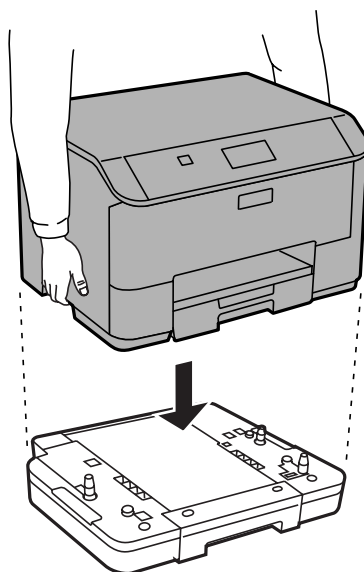

Maintaining Your Product and Software

- 4 Reconnect all the interface cables and the power cord.
- 5 Plug the product's power cord into an electrical outlet.
- 6 Turn on the product.

Enabling the optional cassette on the printer driver

To enable the optional cassette, access the printer properties and make the following settings.

Windows

- 1 Access the printer properties.
➔ ["Accessing printer properties for Windows" on page 29](#)
- 2 Select the **Optional Settings** tab, and then select **Acquire from Printer** from Printer Information. Next, click the **Get** button.
- 3 Click the **OK** button to close the window.

Mac OS X

- 1 Open **System Preferences**, and then double-click the **Print & Scan** ("**Print & Fax**" for OS X 10.6 or 10.5) icon.
- 2 Select the printer from the list, select **Options & Supplies** ("**Open Print Queue**", and then click "**Info**" for OS X 10.5).
- 3 Click the **Driver** tab, and then select **Cassette 2** as the **Lower Cassette**.
- 4 Click the **OK** button.

Uninstalling the cassette unit

Perform the installation procedure in reverse.

Checking the Print Head Nozzles

If you find that the printout is unexpectedly faint or that dots are missing, you may be able to identify the problem by checking the print head nozzles.

You can check the print head nozzles from your computer by using the Nozzle Check utility or from the product by using the buttons.

Using the Nozzle Check utility for Windows

Follow the steps below to use the Nozzle Check utility.

Maintaining Your Product and Software

- 1 Make sure that no warnings or errors are indicated in the control panel.
- 2 Make sure that A4-size paper is loaded in the paper cassette.
- 3 Right-click the product icon on the taskbar, then select **Nozzle Check**.
If the product icon does not appear, refer to the following section to add the icon.
➔ [“From the shortcut icon on the taskbar” on page 29](#)
- 4 Follow the on-screen instructions.

Using the Nozzle Check utility for Mac OS X

Follow the steps below to use the Nozzle Check utility.

- 1 Make sure that no warnings or errors are indicated in the control panel.
- 2 Make sure that A4-size paper is loaded in the paper cassette.
- 3 Access the Epson Printer Utility 4.
➔ [“Accessing the printer driver for Mac OS X” on page 29](#)
- 4 Click the **Nozzle Check** icon.
- 5 Follow the on-screen instructions.

Using the control panel

Follow the steps below to check the print head nozzles using the product control panel.

- 1 Make sure that no warnings or errors are indicated in the control panel.
- 2 Make sure that A4-size paper is loaded in the paper cassette.
- 3 Enter **Menu** from the Home screen.
- 4 Select **Maintenance**.
- 5 Select **Print Head Nozzle Check**, and then follow the instructions on the LCD screen to print a nozzle check pattern.

Maintaining Your Product and Software

6

Below are two sample nozzle check patterns.

Compare the quality of the printed check page with the sample shown below. If there are no print quality problems, such as gaps or missing segments in the test lines, the print head is fine.

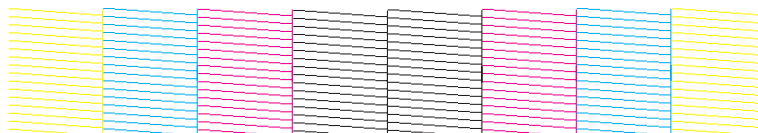

If any segment of the printed lines is missing, as shown below, this could mean a clogged ink nozzle or a misaligned print head.



➔ [“Cleaning the Print Head” on page 67](#)

➔ [“Aligning the Print Head” on page 69](#)

Cleaning the Print Head

If you find that the printout is unexpectedly faint or that dots are missing, you may be able to solve these problems by cleaning the print head, which ensures that the nozzles are delivering ink properly.

You can clean the print head from your computer using the Head Cleaning utility in the printer driver or from the product by using the buttons.



Important:

Do not turn off the product during head cleaning. If the head cleaning is incomplete, you may not be able to print.

Note:

- Do not open the front cover during head cleaning.
- Use the Nozzle Check utility first to confirm that the print head needs to be cleaned. This saves ink.
 - ➔ [“Checking the Print Head Nozzles” on page 65](#)
- Because print head cleaning uses some ink from all cartridges, clean the print head only if quality declines; for example, if the printout is blurry or the color is incorrect or missing.
- When ink is low you may not be able to clean the print head. When ink is expended you cannot clean the print head. Replace the appropriate ink cartridge first.
- If print quality has not improved after repeating this procedure about four times, turn the product off and wait for at least six hours. Then run the nozzle check again and repeat the head cleaning if necessary. If print quality has still not improved, contact Epson support.
- To maintain print quality, we recommend printing a few pages on a regular basis.

Using the Head Cleaning utility for Windows

Follow the steps below to clean the print head using the Head Cleaning utility.

- 1 Make sure that no warnings or errors are indicated in the control panel.
- 2 Right-click the product icon on the taskbar, then select **Head Cleaning**.
If the product icon does not appear, refer to the following section to add the icon.
➔ [“From the shortcut icon on the taskbar” on page 29](#)
- 3 Follow the on-screen instructions.

Using the Head Cleaning utility for Mac OS X

Follow the steps below to clean the print head using the Head Cleaning utility.

- 1 Make sure that no warnings or errors are indicated in the control panel.
- 2 Access the Epson Printer Utility 4.
➔ [“Accessing the printer driver for Mac OS X” on page 29](#)
- 3 Click the **Head Cleaning** icon.
- 4 Follow the on-screen instructions.

Using the control panel

Follow the steps below to clean the print head using the product control panel.

- 1 Make sure that no warnings or errors are indicated in the control panel.
- 2 Enter **Menu** from the Home screen.
- 3 Select **Maintenance**.
- 4 Select **Print Head Cleaning**.
- 5 Follow the instructions on the LCD screen to continue.

Aligning the Print Head

If you notice a misalignment of vertical lines or horizontal banding, you may be able to solve this problem by using the Print Head Alignment utility in your printer driver or by using the product buttons.

Refer to the appropriate section below.

Note:

Do not cancel printing while printing a test pattern with the Print Head Alignment utility.

Using the Print Head Alignment utility for Windows

Follow the steps below to align the print head using the Print Head Alignment utility.

- 1 Make sure that no warnings or errors are indicated in the control panel.
- 2 Make sure A4-size paper is loaded in the paper cassette 1.
- 3 Right-click the product icon on the taskbar, then select **Print Head Alignment**.
If the product icon does not appear, refer to the following section to add the icon.
➔ [“From the shortcut icon on the taskbar” on page 29](#)
- 4 Follow the on-screen instructions to align the print head.

Using the Print Head Alignment utility for Mac OS X

Follow the steps below to align the print head using the Print Head Alignment utility.

- 1 Make sure that no warnings or errors are indicated in the control panel.
- 2 Make sure A4-size paper is loaded in the paper cassette 1.
- 3 Access the Epson Printer Utility 4.
➔ [“Accessing the printer driver for Mac OS X” on page 29](#)
- 4 Click the **Print Head Alignment** icon.
- 5 Follow the on-screen instructions to align the print head.

Using the control panel

Follow the steps below to align the print head using the product control panel.

- 1 Make sure that no warnings or errors are indicated in the control panel.
- 2 Make sure that A4-size paper is loaded in the paper cassette 1.
- 3 Enter **Menu** from the Home screen.
- 4 Select **Maintenance**.
- 5 Select **Print Head Alignment**.
- 6 Select **Ruled Line Alignment**, **Vertical Alignment** or **Horizontal Alignment**, and then follow the on-screen instructions to print an alignment pattern.

Note:

If vertical ruled lines do not look straight, select Ruled Line Alignment. If your printouts look blurry, select Vertical Alignment. If you see horizontal banding at regular intervals, select Horizontal Alignment.

- 7 When you selected Ruled Line Alignment, find the least separated pattern with the straightest line.

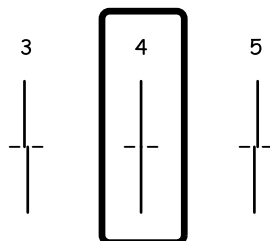

When you selected Vertical Alignment, find the most solid pattern in each of #1 to #6 groups, then enter the pattern number.

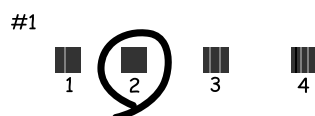

Maintaining Your Product and Software

When you selected Horizontal Alignment, find the least separated and overlapped pattern.

**8**

Finish aligning the print head.

Making Network Service Settings

Web Config

You can make network service settings such as Epson Connect, AirPrint, or Google Cloud Print using a Web browser on your computer, smartphone, tablet PC, or laptop that is connected to the same network as the product.

Enter the product's IP address in the address bar of the Web browser and search for the product.

<Example>

[IPv4] <http://192.168.11.46>

[IPv6] [http://\[fe80::226:abff:feff:37cd\]/](http://[fe80::226:abff:feff:37cd]/)

Note:

You can check your product's IP address on the product's control panel or by printing a network status sheet.

Menu > Network Status > Wi-Fi/Network Status

When the product is found successfully, the product's web page is displayed. Select the menu you want.

The web page also allows you to check the product's status and update the product's firmware.

Sharing the Product for Printing

You can setup the printer so that other computers on the network can share it.

The computer connected directly to the printer acts as a server. Other computers on the network access the server and share the printer.

For more details, see the computer's help.

If you want to use the printer over a network, see the Network Guide.

Cleaning the Product

Cleaning the exterior of the product

To keep your product operating at its best, clean it thoroughly several times a year by using the following instructions.

**Important:**

Never use alcohol or thinner to clean the product. These chemicals can damage the product.

Note:

Close the rear paper feed and the output tray when you are not using the product to protect the product from dust.

Cleaning the interior of the product

If your printouts are stained with ink, follow the steps below to clean the roller inside the product.

**Caution:**

Be careful not to touch the parts inside the product.

**Important:**

- Be careful to keep water away from the electronic components.*
- Do not spray the inside of the product with lubricants.*
- Unsuitable oils can damage the mechanism. Contact your dealer or a qualified service person if lubrication is needed.*

1

Make sure that no warnings or errors are indicated in the control panel.

2

Load several sheets of A4-size plain paper in paper cassette 1.

➔ [“Loading Paper into the Paper Cassette” on page 22](#)

Note:

If you are having problems feeding the paper and have a cleaning sheet that came with your Epson genuine paper, load the cleaning sheet in the rear paper feed slot instead of the plain paper.

Maintaining Your Product and Software

3 Enter **Menu** from the Home screen.

4 Select **Maintenance, Paper Guide Cleaning**, and then follow the instructions on the control panel.

Note:

If your printouts are still stained, load A4-size plain paper in another paper source, and then try steps 3 and 4 again.

Replacing Maintenance Box

Checking the maintenance box status

The maintenance box status is shown in the same screen of the ink cartridge status. You can check the status from the printer software or the control panel.

➔ [“Checking the Ink Cartridge Status” on page 54](#)

Handling precautions

Read all of the instructions in this section before replacing the maintenance box.

- Epson recommends the use of a genuine Epson maintenance box. The use of a non-genuine maintenance box may cause damage that is not covered by Epson's warranties, and under certain circumstances, may cause erratic printer behavior. Epson cannot guarantee the quality or reliability of a non-genuine maintenance box.
- Do not dismantle the maintenance box.
- Do not touch the green chip on the side of the maintenance box.
- Keep out of reach of children.
- Do not tilt the used maintenance box until it is placed in the plastic bag provided.
- Do not reuse a maintenance box which has been removed and left detached for a long period.
- Keep the maintenance box away from direct sunlight.
- In some print cycles a very small amount of surplus ink may be collected in the maintenance box. To prevent ink leakage from the maintenance box, the product is designed to stop printing when the absorbing capacity of the maintenance box has reached its limit. Whether and how often this is required will vary according to the number of pages you print, the type of material that you print and the number of cleaning cycles that the product performs. Replace the maintenance box when you are promoted to do so. The Epson Status Monitor, your LCD, or lights on the control panel will advise you when this part needs replacing. The need for replacement of the box does not mean that your product has ceased to operate in accordance with its specifications. The Epson warranty does not cover the cost of this replacement. It is a user-serviceable part.

Replacing a maintenance box

To replace the maintenance box, follow the steps below.

Maintaining Your Product and Software

1 Confirm that the product is not draining the ink.

2 Remove the replacement maintenance box from the package.

Note:

Do not touch the green chip on the side of the box. Doing so may prevent normal operation.

3 Push the buttons on either side of the rear unit at the same time, and then pull the unit out.

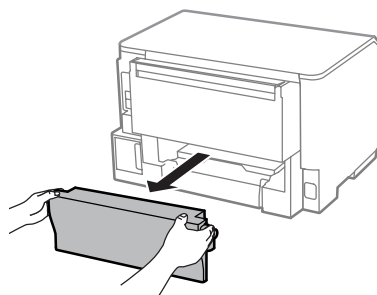

4 Put your hand on the handle of the maintenance box, and then pull the box outward.

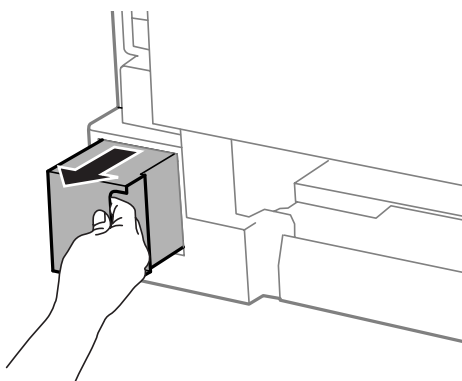

Note:

If ink gets on your hands, wash them thoroughly with soap and water. If ink gets into your eyes, flush them immediately with water.

5 Put the used maintenance box in the plastic bag provided with the replacement box, and dispose of it properly.

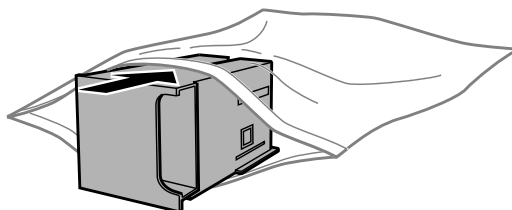

Note:

Do not tilt the used maintenance box until after it is sealed in the plastic bag.

Maintaining Your Product and Software

- 6 Insert the new maintenance box into place as far as it will go.

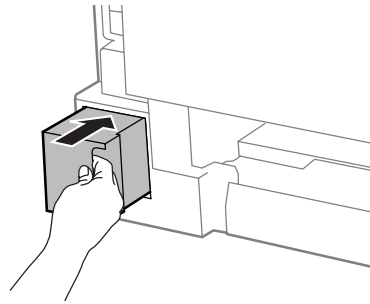

- 7 Push the button on either side of the rear unit at the same time, and then reattach the unit.

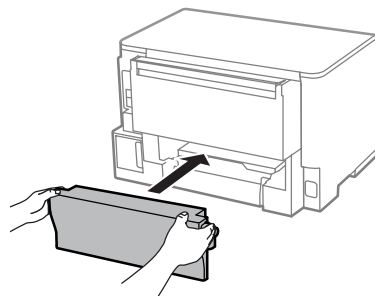

- 8 Press the **OK** button on the control panel.

Maintenance box replacement is complete.

Transporting the Product

If you move the product some distance, you need to prepare it for transportation in its original box or one of a similar size.

! *Important:*

- When storing or transporting the product, avoid tilting it, placing it vertically, or turning it upside down; otherwise ink may leak.*
- Leave the ink cartridges installed. Removing the cartridges can dry out the print head and may prevent the product from printing.*

- 1 Make sure the product is off.
- 2 Unplug its power cord and disconnect all other cables from the product.
- 3 Remove all paper from the rear paper feed.
- 4 Close the rear paper feed and the output tray.

Maintaining Your Product and Software

- 5 Remove all paper from the paper cassette and re-insert the cassette into the product.
- 6 Repack the product in its box, using the protective materials that came with it.

Note:

Keep the product level during transport.

Checking and Installing Your Software

Checking the software installed on your computer

To use the functions described in this User's Guide, you need to install the following software.

- Epson Driver and Utilities

Follow the steps below to check that the software is installed on your computer.

For Windows

- 1 **Windows 8 and Server 2012:** Select **Desktop**, **Settings** charm, and **Control Panel**.
Windows 7, Vista, and Server 2008: Click the start button and select **Control Panel**.
Windows XP and Server 2003: Click **Start** and select **Control Panel**.
- 2 **Windows 8, Windows 7, Vista, Server 2012 and Server 2008:** Select **Uninstall a program** from the Programs category.
Windows XP: Double-click the **Add or Remove Programs** icon.
Windows Server 2003: Click the **Add or Remove Programs** icon.
- 3 Check the list of currently installed programs.

For Mac OS X

- 1 Double-click **Macintosh HD**.
- 2 Double-click the **Epson Software** folder in the Applications folder and check the contents.

Note:

- The Applications folder contains software provided by third parties.
- To check that the printer driver is installed, click **System Preferences** on the Apple menu and then click **Print & Scan** (for Mac OS X 10.8 or 10.7) or **Print & Fax** (for Mac OS X 10.6 or 10.5.8). Then locate your product in the Printers list box.

Installing the software

Insert the product software disk that came with your product and select the software you want to install on the Software Select screen.

If you are using Mac OS X, or if your computer does not have a CD/DVD drive, go to the following Epson website to download and install the software.

<http://support.epson.net/setupnavi/>

Installing the PostScript Printer Driver

This driver is only available for the WF-5190 Series.

System requirements

Printer hardware requirements

	Recommended
Memory	Standard + 128 MB (for duplex printing of image data at Fine)

Computer system requirements

➔ [“System Requirements” on page 102](#)

Note:

*If you use binary data for the network connection, you need to set Binary to **On** in the PS3 Menu on the control panel.
If you use the printer with a local connection, you cannot use binary data.*

Installing the PostScript printer driver with Windows

To print in the PostScript mode, you will have to install the printer driver.

For the USB interface

Note:

- Installing the printer software for Windows may require administrator privileges. If you have problems, ask your administrator for more information.
- Turn off all virus protection programs before installing the printer software.

Maintaining Your Product and Software

- 1 Make sure that the printer is turned off. Insert the printer Software Disc into your CD/DVD drive.

Note:

If your computer does not have a CD/DVD drive, download the driver from the Epson Web site.

<http://www.epson.eu/Support> (Europe)

<http://support.epson.net/> (outside Europe)

- 2 If the printer is connected to a USB interface, connect your computer to the printer with a USB cable, then turn on the printer.

Note for Windows Vista users:

Without the Windows driver or the Adobe PS driver, the display shows "Found New Hardware." In this case, click **Ask me again later**.

- 3 **Windows 8 and Server 2012:** Select **Desktop, Settings** charm, and **Control Panel**. Click **View devices and printers**, then click **Add a printer** button.
Windows 7: Click the start button, select **Devices and Printers**, and click the **Add a printer** button.
Windows Vista, Windows XP, Server 2008: Click **Start**, point to **Printer and Faxes**, and click **Add a printer** in the Printer Tasks menu.
Windows Server 2003: Click **Start**, point to **Settings**, and click **Printers**. Then double-click the **Add Printer** icon.

- 4 The Add Printer Wizard appears. Then click **Next**.

- 5 Select **Local printer**, then click **Next**.

Note:

Do not select the **Automatically detect and install my Plug and Play printer** check box.

- 6 If the printer is connected to a USB interface, select **USB**, then click **Next**.

- 7 Click **Have Disk** and specify the following path for the Software Disc. If your CD/DVD drive is D:, the path will be D:\Driver\PostScript\epsnt.inf. Then click **OK**.

Note:

Change the drive letter as needed for your system.

- 8 Select the printer, then click **Next**.

- 9 Follow the on-screen instructions for the rest of the installation.

- 10 When installation is done, click **Finish**.

Maintaining Your Product and Software

For the network interface

Note:

- Set the network settings before installing the printer driver. Refer to the Network Guide for details.
- Turn off all virus protection programs before installing the printer software.

1 Make sure that the printer is turned on. Insert the printer Software Disc into your CD/DVD drive.

Note:

If your computer does not have a CD/DVD drive, download the driver from the Epson Web site.

<http://www.epson.eu/Support> (Europe)

<http://support.epson.net/> (outside Europe)

2 **Windows 8 and Server 2012:** Select **Desktop, Settings** charm, and **Control Panel**. Click **View devices and printers**, then click **Add a printer** button.

Windows 7: Click the start button, select **Devices and Printers**, and click the **Add a printer** button.

Windows Vista, Windows XP, Server 2008: Click **Start**, point to **Printer and Faxes**, and click **Add a printer** in the Printer Tasks menu.

Windows Server 2003: Click **Start**, point to **Settings**, and click **Printers**. Then double-click the **Add Printer** icon.

3 The Add Printer Wizard appears. Then click **Next**.

4 Select **Local printer**, then click **Next**.

Note:

Do not select the **Automatically detect and install my Plug and Play printer** check box.

5 Select the **Create a new port check box** and select **Standard TCP/IP Port** from the drop-down list. Click **Next**.

6 Click **Next**.

7 Specify the IP address and port name, then click **Next**.

8 Click **Finish**.

9 Click **Have Disk** in the Add Printer Wizard and specify the following path for the Software Disc. If your CD/DVD drive is D:, the path will be D:\Driver\PostScript\eppsnt.inf. Then click **OK**.

Note:

Change the drive letter as needed for your system.

10 Select the printer and click **Next**.

Maintaining Your Product and Software

11 Follow the on-screen instructions for the rest of the installation.

12 When installation is done, click **Finish**.

Installing the PostScript printer driver with Mac OS X

Installing the Post Script printer driver

Go to the following Epson support website to download and install the driver.

<http://www.epson.eu/Support> (Europe)

<http://support.epson.net/> (outside Europe)

Selecting the printer

After installing the PostScript 3 printer driver, you need to select the printer.

Note:

- You need to make the settings for your installed options manually when the printer is connected using USB, IP printing, or Bonjour.
- Make sure to specify ASCII as the data format in the application.

1 Open the System Preferences, and then double-click the Print & Fax (“Print & Scan” for Mac OS X 10.8 or 10.7) icon.
The Print & Fax (“Print & Scan” for Mac OS X 10.8 or 10.7) window appears.

2 Click + add button in the Printers window.

3 Select the printer name that you are using from the printer name box.

Note:

If your printer is not listed, check that it is correctly connected to the computer and that the printer is on.

4 Click **Add**.

5 Confirm that your printer's name is added to the Printers list. Then quit **Print & Fax** (“**Print & Scan**” for Mac OS X 10.8 or 10.7).

Installing the Epson Universal Printer Driver (for Windows Only)

Note:

This driver is only available for the WF-5190 Series.

Maintaining Your Product and Software

Epson universal printer driver is the universal PCL6 compatible print driver that has the following features:

- It supports the basic print functions needed for business situations.
- It supports multiple Epson business printers besides this printer.
- It supports most languages among the print drivers for this printer.

Computer system requirements

See the following for the Windows System Requirements.

➔ [“For Windows” on page 102](#)

Installing the Printer Driver

You may need the printer's IP address while installing the printer driver. Check the IP address by selecting **Menu > Network Status > Wi-Fi/Network Status** on the control panel.

- 1** Download the driver's executable file from the Epson support website.
<http://www.epson.eu/Support> (Europe)
<http://support.epson.net/> (outside Europe)

Note:

We recommend downloading the latest driver from the website. However you can also find it on the software disc that came with the printer. Access "Driver\PCLUniversal" or "Driver\Universal".

- 2** Double-click the executable file that you downloaded from the website or that is on the software disc.
- 3** Follow the on-screen instructions for the rest of the installation.

Uninstalling Your Software

You may need to uninstall and then reinstall your software to solve certain problems or if you upgrade your operating system.

See the following section for information on determining what applications are installed.

➔ [“Checking the software installed on your computer” on page 76](#)

For Windows

Note:

- For Windows 8, 7, Vista, Server 2012 and Server 2008, you need an administrator account and password if you log on as a standard user.
- For Windows XP and Server 2003, you must log on to a Computer Administrator account.

Maintaining Your Product and Software

- 1** Turn off the product.
 - 2** Disconnect the product's interface cable from your computer.
 - 3** Do one of the following.
 - Windows 8 and server 2012:** Select **Desktop**, **Settings** charm, and **Control Panel**.
 - Windows 7, Vista, and Server 2008:** Click the start button and select **Control Panel**.
 - Windows XP and Server 2003:** Click **Start** and select **Control Panel**.
 - 4** Do one of the following.
 - Windows 8, Windows 7, Vista, Server 2012 and Server 2008:** Select **Uninstall a program** from the Programs category.
 - Windows XP:** Double-click the **Add or Remove Programs** icon.
 - Windows Server 2003:** Click the **Add or Remove Programs** icon.
 - 5** Select the software you want to uninstall such as your product's driver and the application from the list displayed.
 - 6** Do one of the following.
 - Windows 8, Windows 7, Server 2012 and Server 2008:** Select **Uninstall/Change** or **Uninstall**.
 - Windows Vista:** Click **Uninstall/Change** or **Uninstall**, and then click **Continue** in the User Account Control window.
 - Windows XP and Server 2003:** Click **Change/Remove** or **Remove**.
- Note:**
*If you chose to uninstall your product's printer driver in step 5, select the icon for your product and then click **OK**.*
- 7** When the confirmation window appears, click **Yes** or **Next**.
 - 8** Follow the on-screen instructions.

In some cases, a message may appear to prompt you to restart your computer. If so, make sure **I want to restart my computer now** is selected and click **Finish**.

For Mac OS X

Note:

- To uninstall your software you need to download the Uninstaller.
Access the site at:
<http://www.epson.com>
Next, select the support section of your local Epson Web site.
- To uninstall applications, you must log on to a Computer Administrator account.
You cannot uninstall programs if you log on as a limited account user.
- Depending on the application, the Installer may be separated from the Uninstaller.

- 1** Quit all running applications.
- 2** Double-click the **Uninstaller** icon in your Mac OS X hard drive.
- 3** Select the check boxes for the software you want to uninstall, such as the printer driver and the application, from the list displayed.
- 4** Click **Uninstall**.
- 5** Follow the on-screen instructions.

If you cannot find the software you want to uninstall in the Uninstaller window, double-click the **Applications** folder in your Mac OS X hard drive, select the application you want to uninstall, and then drag it to the **Trash** icon.

Note:

*If you uninstall the printer driver and the name of your product remains in the Print & Scan (for Mac OS X 10.8 or 10.7) or Print & Fax (for Mac OS X 10.6 or 10.5.8) window, select the name of your product and click the - **remove** button.*

Error Indicators

Error Messages on the Control Panel

This section describes the meaning of messages displayed on the LCD screen.

Messages	Solutions
Paper Jam	➔ "Paper Jams" on page 88
Printer Error	Turn the product off and then back on. Make sure that no paper is still in the product. If the error still appears, contact Epson Support.
Maintenance box is at the end of its service life. You need to replace it.	Replace the maintenance box. ➔ "Replacing Maintenance Box" on page 73
Invalid IP address and subnet mask.	Refer the online Network Guide.
Memory Full	Reduce the size of the print job.
Recovery Mode	The firmware update has failed. You will need to re-attempt the firmware update. Ready a USB cable and visit your local Epson website for further instructions. ➔ "Where To Get Help" on page 119

Troubleshooting for Printing

Diagnosing the Problem

Troubleshooting product problems is best handled in two steps: first diagnose the problem, then apply likely solutions until the problem is fixed.

The information that you need to diagnose and solve most common problems is provided by online problem solving, the control panel, or the status monitor. Refer to the appropriate section below.

If you have a specific problem relating to print quality, a printing problem not related to print quality, or a paper feeding problem, or if the product does not print at all, refer to the appropriate section.

To solve a problem, you may need to cancel printing.

➔ [“Canceling printing” on page 34](#)

Troubleshooting for Printing

Checking product status

If a problem occurs while printing, an error message will appear in the status monitor window.

When you need to replace an ink cartridge or a maintenance box, click the **How To** button on the window, and the status monitor will lead you step-by-step through the cartridge or the maintenance box replacement procedure.

For Windows

There are two ways to access EPSON Status Monitor 3:

- Double-click the product shortcut icon on your Windows taskbar. To add a shortcut icon to the taskbar, see the following section:
 - ➔ [“From the shortcut icon on the taskbar” on page 29](#)
- Open the printer driver, click the **Maintenance** tab, then click the **EPSON Status Monitor 3** button.

When you access EPSON Status Monitor 3, the following window appears:



Note:

- If EPSON Status Monitor 3 does not appear, access the printer driver and click the **Maintenance** tab and then the **Extended Settings** button. In the Extended Settings window, check the **Enable EPSON Status Monitor 3** check box.
- Depending on current settings, the simplified status monitor may be displayed. Click the **Details** button to display the window above.

EPSON Status Monitor 3 provides the following information:

Troubleshooting for Printing

- ❑ **Current Status:**
If the ink is low/expended or the maintenance box is nearly full/full, the **How to** button appears in the EPSON Status Monitor 3 window. Clicking **How to** displays ink cartridge or maintenance box replacement instructions.
- ❑ **Ink Levels:**
EPSON Status Monitor 3 provides a graphic display of the ink cartridge status.
- ❑ **Information:**
You can view information about the installed ink cartridges by clicking **Information**.
- ❑ **Maintenance Box Service Life:**
EPSON Status Monitor 3 provides a graphic display of the maintenance box status.
- ❑ **Technical Support:**
Click **Technical Support** to access the Epson technical support website.
- ❑ **Print Queue:**
You can view Windows Spooler by clicking **Print Queue**.

For Mac OS X

Follow these steps to access EPSON Status Monitor.

- 1 Access the Epson Printer Utility 4.
➔ [“Accessing the printer driver for Mac OS X” on page 29](#)
- 2 Click the **EPSON Status Monitor** icon. The EPSON Status Monitor appears.



Troubleshooting for Printing

You can also use this utility to check the ink cartridge status before printing. EPSON Status Monitor displays the ink cartridge status at the time it was opened. To update the ink cartridge status, click **Update**.

When ink is low/expended or the maintenance box is nearly full/full, a **How to** button appears. Click **How to**, and EPSON Status Monitor will lead you step by step through the ink cartridge or maintenance box replacement procedure.

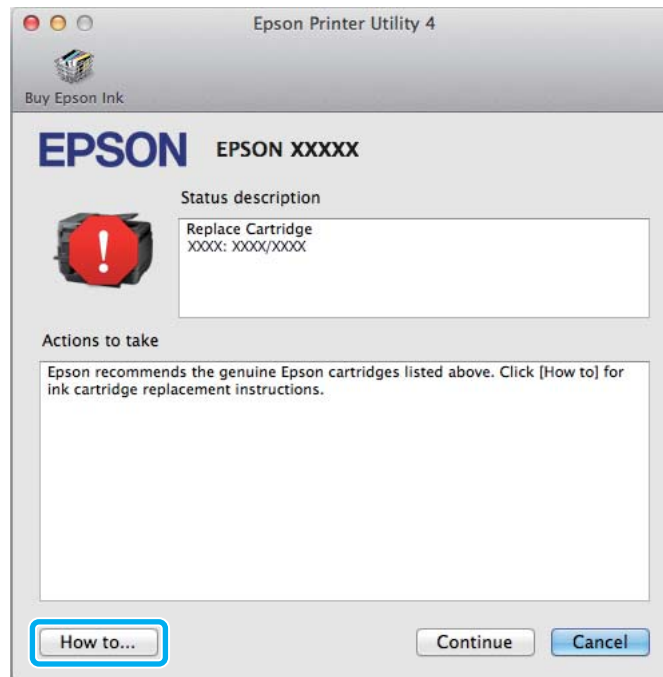

Paper Jams



Caution:

Never touch the buttons on the control panel while your hand is inside the product.

Note:

- Cancel the print job if prompted by a message from the LCD screen or the printer driver.
- After you have removed the jammed paper, press the button indicated in the LCD screen.

Troubleshooting for Printing

Removing jammed paper from the rear unit

- 1 Push the buttons on either side of the rear unit at the same time, and then pull the unit out.

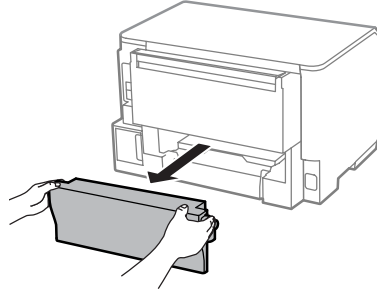

- 2 Carefully remove the jammed paper.

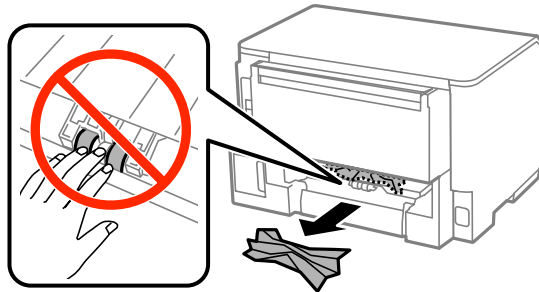

- 3 Carefully remove the jammed paper.

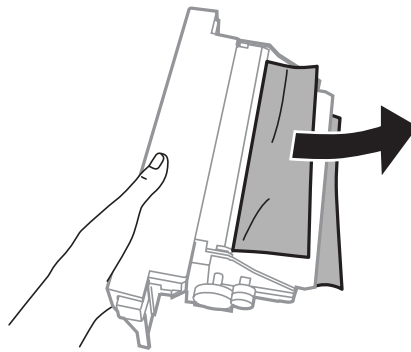

- 4 Push the button on either side of the rear unit at the same time, and then reattach the unit.

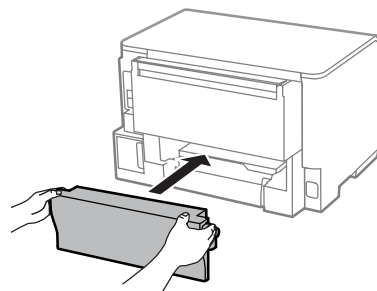

Troubleshooting for Printing

Removing jammed paper from the front cover and the output tray

- 1 Open the front cover.

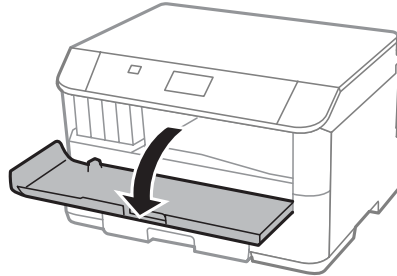

- 2 Remove all of the paper inside, including any torn pieces.

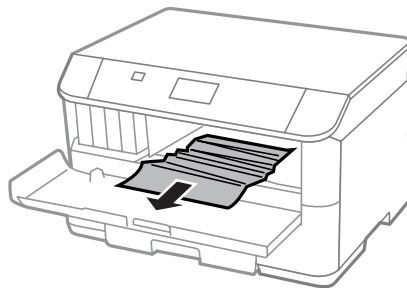

- 3 Close the front cover. If the jammed paper remains near the output tray, carefully remove the paper.

Removing jammed paper from the paper cassette

- 1 Pull out the paper cassette.

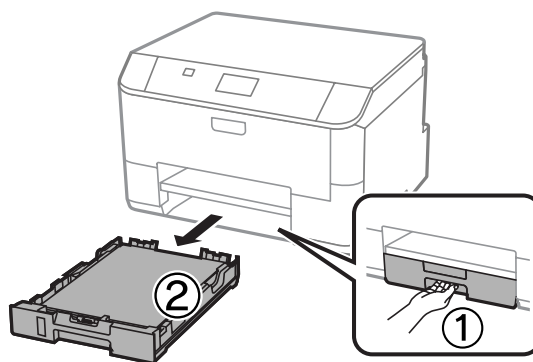

Troubleshooting for Printing

- 2** Carefully remove any paper jammed inside the printer.

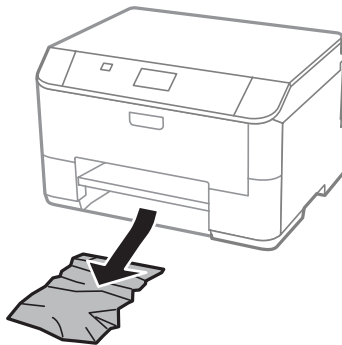

- 3** Reload the paper into the paper cassette.
 ➔ [“Loading Paper into the Paper Cassette” on page 22](#)

- 4** Keep the cassette flat and insert it back into the printer carefully and slowly.

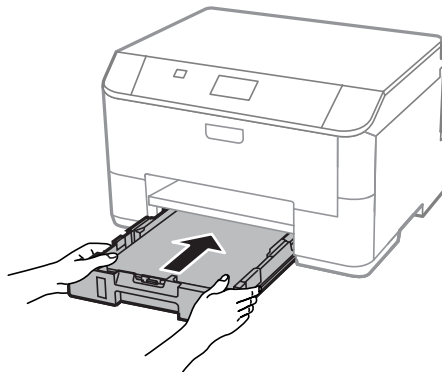

Preventing paper jams

If your paper jams frequently, check the following.

- The paper is smooth, not curled or wrinkled.
- You are using high-quality paper.
- The printable side of the paper is face down in the paper cassette.
- The printable side of the paper is face up in the rear paper feed.
- The paper stack was fanned before loading.
- For plain paper, do not load paper above the line just under the ▼ arrow mark inside the edge guide. For Epson special media, make sure the number of sheets is less than the limit specified for the media.
 ➔ [“Selecting Paper” on page 18](#)
- The edge guides are snug against the edges of the paper.
- The product is on a flat, stable surface that extends beyond the base in all directions. The product will not operate properly if it is tilted.

Troubleshooting for Printing

Reprinting after a paper jam (for Windows only)

After you cancel the print job because of a paper jam, you can reprint it without reprinting pages that have already been printed.

- 1 Solve the paper jam.
➔ [“Paper Jams” on page 88](#)
- 2 Access the printer settings.
➔ [“Accessing the printer driver for Windows” on page 28](#)
- 3 Select the **Print Preview** check box in the Main window of your printer driver.
- 4 Make the settings that you want to use to print.
- 5 Click **OK** to close the printer settings window, and then print your file. Print Preview window opens.
- 6 Select a page that has already been printed in the page list box on the left side, and then select **Remove Page** from the Print Options menu. Repeat this step for all the pages that have already been printed.
- 7 Click **Print** on the Print Preview window.

Print Quality Help

If you are having print quality problems, then compare it with the illustrations below. Click the caption under the illustration that best resembles your prints.

<p>enthalten alle Aufdruck. W 5008 "Regel</p> <p>Good sample</p>	 <p>Good sample</p>
<p>enthalten alle Aufdruck. W 5008 "Regel</p> <p>➔ “Horizontal banding” on page 93</p>	<p>enthalten alle Aufdruck. W 5008 "Regel</p> <p>➔ “Vertical banding or misalignment” on page 93</p>

Troubleshooting for Printing

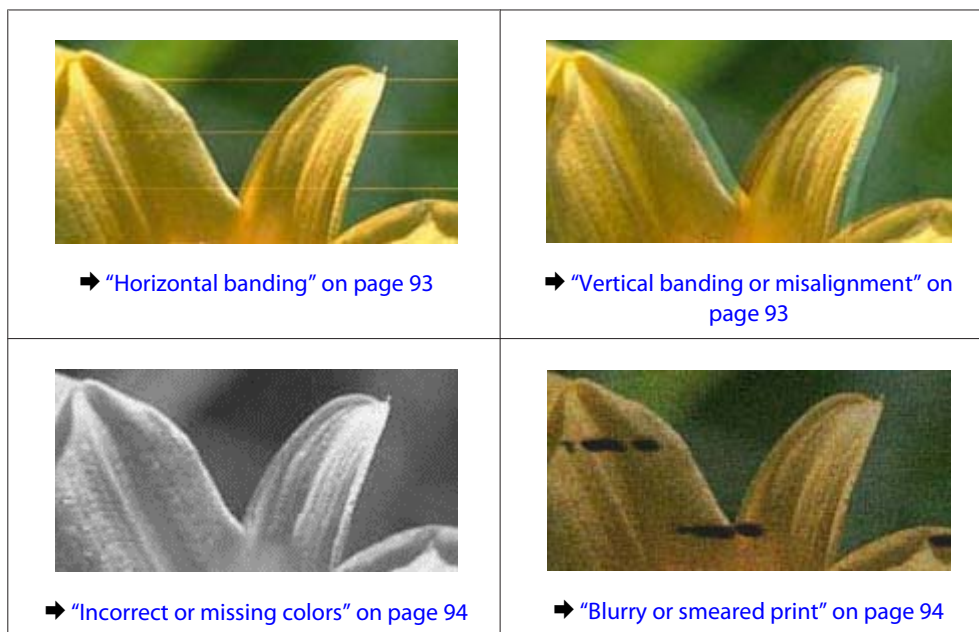

Horizontal banding

- ❑ Make sure the printable side (the whiter or glossier side) of the paper is face up in the rear paper feed.
- ❑ Make sure the printable side (the whiter or glossier side) of the paper is face down in the paper cassette.
- ❑ Run the Nozzle Check utility and then clean any print heads which produced a defective nozzle check result.
 - ➔ [“Checking the Print Head Nozzles” on page 65](#)

If the problem does not improve, run the Print Head Alignment utility.

➔ [“Aligning the Print Head” on page 69](#)

- ❑ For best results, use up ink cartridge within six months of opening the package.
- ❑ Try to use genuine Epson ink cartridges.
- ❑ Make sure the paper type selected in the LCD menu or printer driver is appropriate for the type of paper loaded in the product.
 - ➔ [“Selecting Paper” on page 18](#)

Vertical banding or misalignment

- ❑ Make sure the printable side (the whiter or glossier side) of the paper is face up in the rear paper feed.
- ❑ Make sure the printable side (the whiter or glossier side) of the paper is face down in the paper cassette.
- ❑ Run the Nozzle Check utility and then clean any print heads which produced a defective nozzle check result.
 - ➔ [“Checking the Print Head Nozzles” on page 65](#)
- ❑ Run the Print Head Alignment utility.
 - ➔ [“Aligning the Print Head” on page 69](#)

Troubleshooting for Printing

- ❑ For Windows, clear the **High Speed** check box from the More Options window in your printer driver. See the online help for details.
For Mac OS X, select **Off** from the High Speed Printing. To display the High Speed Printing, click through the following menus: **System Preferences, Print & Scan** (for Mac OS X 10.8 or 10.7) or **Print & Fax** (for Mac OS X 10.6 or 10.5.8), your product (in the Printers list box), **Options & Supplies**, and then **Driver**.
- ❑ Make sure the paper type selected in the LCD menu or printer driver is appropriate for the type of paper loaded in the product.
➔ [“Selecting Paper” on page 18](#)
- ❑ For Windows, if you have selected Standard-Vivid as Quality in your printer driver's Main tab, change it to Standard.
For Mac OS X, if you have selected Normal-Vivid as Print Quality in your printer driver's Print Settings from the pop-up menu, change it to Normal.

Incorrect or missing colors

- ❑ For Windows, clear the **Grayscale** setting in the Main window in your printer driver.
For Mac OS X, clear the **Grayscale** setting in Print Settings in the Print dialog box in your printer driver.
- ❑ Adjust the color settings in your application or in your printer driver settings.
For Windows, check the More Options window.
For Mac OS X, check the Color Options dialog box from the Print dialog box.
- ❑ Run the Nozzle Check utility and then clean any print heads which produced a defective nozzle check result.
➔ [“Checking the Print Head Nozzles” on page 65](#)
- ❑ If you have just replaced an ink cartridge, make sure the date on the box. If you have not used the product for a long time, Epson recommends replacing the ink cartridges.
➔ [“Replacing an ink cartridge” on page 61](#)
- ❑ Try to use genuine Epson ink cartridges and paper recommended by Epson.

Blurry or smeared print

- ❑ Try to use genuine Epson ink cartridges and paper recommended by Epson.
- ❑ Make sure the product is on a flat, stable surface that extends beyond the base in all directions. The product will not operate properly if it is tilted.
- ❑ Make sure your paper is not damaged, dirty, or too old.
- ❑ Make sure your paper is dry and the printable side (the whiter or glossier side) is face up in the rear paper feed.
- ❑ Make sure your paper is dry and the printable side (the whiter or glossier side) is face down in the paper cassette.
- ❑ If the paper is curled toward the printable side, flatten it or curl it slightly in the opposite direction.
- ❑ Make sure the paper type selected in the LCD menu or printer driver is appropriate for the type of paper loaded in the product.
➔ [“Selecting Paper” on page 18](#)
- ❑ Remove each sheet from the output tray as it is printed.

Troubleshooting for Printing

- ❑ Do not touch or allow anything to come into contact with the printed side of paper with a shiny finish. To handle your prints, follow the instructions of the paper.
- ❑ Run the Nozzle Check utility and then clean any print heads which produced a defective nozzle check result.
 - ➔ [“Checking the Print Head Nozzles” on page 65](#)
- ❑ Run the Print Head Alignment utility.
 - ➔ [“Aligning the Print Head” on page 69](#)
- ❑ From the product's control panel, select the menu as shown below.
Menu > Maintenance > Thick Paper > On

For Windows, select **Thick paper and envelopes** from Extended Settings in your printer driver's Maintenance tab.

For Mac OS X 10.5.8, select **On** from the Thick paper and envelopes. To display the Thick Paper and Envelopes, click through the following menus: **System Preferences, Print & Scan** (for Mac OS X 10.8 or 10.7) or **Print & Fax** (for Mac OS X 10.6 or 10.5.8), your product (in the Printers list box), **Options & Supplies**, and then **Driver**.

- ❑ If you are printing high-density data on plain paper using automatic 2-sided printing, lower the Print Density and choose a longer Increase Ink Drying Time in the Print Density Adjustment window (for Windows) or in the Two-sided Printing Settings (for Mac OS X) of your printer driver. The longer the Increase Ink Drying Time is, the longer it takes to print.
- ❑ For Windows, select **High** as the Quality setting on the Main tab.
For Mac OS X, select **Fine** as the Print Quality in the Print Settings pane from the Print dialog box.
- ❑ If the paper is smeared with ink after printing, clean the interior of the product.
 - ➔ [“Cleaning the interior of the product” on page 72](#)

Miscellaneous Printout Problems

Incorrect or garbled characters

- ❑ Clear any stalled print jobs.
 - ➔ [“Canceling printing” on page 34](#)
- ❑ Turn off the product and computer. Make sure the product's interface cable is securely plugged in.
- ❑ Uninstall the printer driver, then reinstall it.
 - ➔ [“Uninstalling Your Software” on page 81](#)
- ❑ If you put your computer into Hibernate or Sleep mode manually while the computer is sending a print job, pages of garbled text may be printed the next time you start your computer.

Incorrect margins

- ❑ Make sure that the paper is loaded into the rear paper feed or the paper cassette correctly.
 - ➔ [“Loading Paper into the Paper Cassette” on page 22](#)
 - ➔ [“Loading Paper and Envelopes into the Rear Paper Feed” on page 25](#)

Troubleshooting for Printing

- ❑ Check the margin settings in your application. Make sure that the margins are within the printable area of the page.
 - ➔ [“Printable area” on page 103](#)
 - ❑ Make sure the printer driver settings are appropriate for the paper size you are using.
For Windows, check the Main window.
For Mac OS X, check the Page Setup dialog box or Print dialog box.
 - ❑ Uninstall the printer driver, then reinstall it.
 - ➔ [“Uninstalling Your Software” on page 81](#)
-

Printout has a slight slant

- ❑ Make sure that the paper is loaded into the rear paper feed or the paper cassette correctly.
 - ➔ [“Loading Paper into the Paper Cassette” on page 22](#)
 - ➔ [“Loading Paper and Envelopes into the Rear Paper Feed” on page 25](#)
 - ❑ If Draft is selected in Quality in the Main window in your printer driver (for Windows), or in Print Quality in Print Settings (for Mac OS X), select another setting.
-

Inverted image

- ❑ For Windows, clear the **Mirror Image** check box from the More Options window of your printer driver, or turn off the Mirror Image setting in your application.
For Mac OS X, clear the **Mirror Image** check box in **Print Settings** in the Print dialog box of your printer driver, or turn off the Mirror Image setting in your application.
 - ❑ Uninstall the printer driver, then reinstall it.
 - ➔ [“Uninstalling Your Software” on page 81](#)
-

Blank pages print

- ❑ Make sure the printer driver settings are appropriate for the paper size you are using.
For Windows, check the Main window.
For Mac OS X, check the Page Setup dialog box or Print dialog box.
 - ❑ For Windows, check the **Skip Blank Page** setting by clicking the **Extended Settings** button on the Maintenance window of the printer driver.
For Mac OS X, select **On** from the Skip Blank Page. To display the Skip Blank Page, click through the following menus: **System Preferences, Print & Scan** (for Mac OS X 10.8 or 10.7) or **Print & Fax** (for Mac OS X 10.6 or 10.5.8), your product (in the Printers list box), **Options & Supplies**, and then **Driver**.
 - ❑ Uninstall the printer driver, then reinstall it.
 - ➔ [“Uninstalling Your Software” on page 81](#)
-

Printed side is smeared or scuffed

- ❑ If the paper is curled toward the printable side, flatten it or curl it slightly in the opposite direction.

Troubleshooting for Printing

- ❑ Clean the interior of the product by using the Paper Guide Cleaning function.
➔ [“Cleaning the interior of the product” on page 72](#)
- ❑ Uninstall the printer driver, then reinstall it.
➔ [“Uninstalling Your Software” on page 81](#)

Printing is too slow

- ❑ Make sure the paper type selected in the LCD menu or printer driver is appropriate for the type of paper loaded in the product.
➔ [“Selecting Paper” on page 18](#)
- ❑ Choose a lower print quality in the printer driver's Main window (Windows), or in the Print Settings dialog box from the printer driver's Print dialog box (Mac OS X).
➔ [“Accessing the printer driver for Windows” on page 28](#)
➔ [“Accessing the printer driver for Mac OS X” on page 29](#)
- ❑ When Increase Ink Drying Time settings is changed, the print speed may decline. Choose a shorter time for Increase Ink Drying Time in the Print Density Adjustment window (for Windows) or in the Two-sided Printing Settings (for Mac OS X) of your printer driver.
- ❑ Close any unnecessary applications.
- ❑ If you print continuously for an extended period, the printing may be extremely slow. This is to slow down the printing speed and prevent the product mechanism from overheating and being damaged. However, you can continue printing. To return the printer to normal printing speed, leave the printer idle for at least 30 minutes. The printer does not recover if the power is off.
- ❑ Uninstall the printer driver, then reinstall it.
➔ [“Uninstalling Your Software” on page 81](#)

If you try all of the methods above and cannot solve the problem, see the following.

Paper Does Not Feed Correctly

Paper does not feed

Remove the stack of paper and make sure of the following:

- ❑ You have inserted the paper cassette all the way into the product.
- ❑ The paper is not curled or creased.
- ❑ The paper is not too old. See the instructions that came with the paper for more information.
- ❑ For plain paper, do not load paper above the line just under the ▼ arrow mark inside the edge guide. For Epson special media, make sure the number of sheets is less than the limit specified for the media.
➔ [“Selecting Paper” on page 18](#)
- ❑ Paper is not jammed inside the product. If it is, remove the jammed paper.
➔ [“Paper Jams” on page 88](#)

Troubleshooting for Printing

- ❑ The ink cartridges are not expended. If a cartridge is expended, replace it.
➔ [“Replacing an ink cartridge” on page 61](#)
- ❑ You have followed any special loading instructions that came with your paper.
- ❑ Clean the interior of the product.
➔ [“Cleaning the interior of the product” on page 72](#)

Multiple pages feed

- ❑ For plain paper, do not load paper above the line just under the ▼ arrow mark inside the edge guide. For Epson special media, make sure the number of sheets is less than the limit specified for the media.
➔ [“Selecting Paper” on page 18](#)
- ❑ Make sure the edge guides are snug against the edges of the paper.
- ❑ Make sure the paper is not curled or folded. If so, flatten it or curl it slightly toward the opposite side before loading.
- ❑ Remove the stack of paper and make sure that the paper is not too thin.
➔ [“Paper” on page 103](#)
- ❑ Fan the edges of the stack to separate the sheets, then reload the paper.

Paper Cassette 2 is not displayed on the printer driver

After installing the optional paper cassette, you need to enable the cassette on the printer driver.

- ➔ [“Enabling the optional cassette on the printer driver” on page 65](#)

Paper is improperly loaded

If you have loaded the paper too far into the product, the product cannot feed the paper correctly. Turn the product off and gently remove the paper. Then turn the product on and reload the paper correctly.

Paper is not ejected fully or is wrinkled

- ❑ If the paper does not eject fully, press the button indicated on the control panel to eject the paper. If the paper is jammed inside the product, remove it by referring to the following section.
➔ [“Paper Jams” on page 88](#)
- ❑ If the paper is wrinkled when it comes out, it may be damp or too thin. Load a new stack of paper.

Note:

Store any unused paper in its original packaging in a dry area.

The Product Does Not Print

All lights are off

- Press the  button to make sure the product is on.
- Make sure that the power cord is securely plugged in.
- Make sure that your outlet works and is not controlled by a wall switch or timer.

Lights came on and then went out

The product's voltage may not match the outlet rating. Turn off the product and unplug it immediately. Then check the label on the back of the product.

**Caution:**

If the voltage does not match, DO NOT PLUG YOUR PRODUCT BACK IN. Contact your dealer.

The control panel or lights are on

- Turn off the product and computer. Make sure the product's interface cable is securely plugged in.
- If you are using the USB interface, make sure your cable meets the USB or Hi-Speed USB standards.
- If you are connecting the product to your computer via a USB hub, connect the product to the first-tier hub from your computer. If the printer driver is still not recognized on your computer, try to directly connect the product to your computer without the USB hub.
- If you are connecting the product to your computer via a USB hub, make sure the USB hub device is recognized by your computer.
- If you are trying to print a large image, your computer may not have enough memory. Try reducing the resolution of your image or printing the image at a smaller size. You may need to install more memory in your computer.
- Users of Windows can clear any stalled print jobs from the Windows Spooler.
 - ➔ [“Canceling printing” on page 34](#)
- Uninstall the printer driver, then reinstall it.
 - ➔ [“Uninstalling Your Software” on page 81](#)

Using the PostScript Printer Driver

Note:

Depending on your computer's environment, the actual menu and text on the printer driver may differ.

Troubleshooting for Printing

The product does not print

- ❑ Check that the Printing Language is set to Auto or PS3 on the product.
 - ➔ [“System Administration Settings” on page 46](#)
- ❑ In Windows, if a large number of jobs are sent, print data may not be sent correctly from the spooler. In this case, select Print directly to the printer from the printer's properties on the computer.
 - ➔ [“Accessing printer properties for Windows” on page 29](#)
- ❑ If you cannot print text data, even when Text detection is set to On from the product, check that the Printing Language is set to PS3.
 - ➔ [“System Administration Settings” on page 46](#)

The product does not print correctly

- ❑ If the file is created in an application that allows you to change the data format or encoding, such as Photoshop, make sure that the settings in the application match the settings in the printer driver. EPS files made in binary format may not be printed correctly. Set the format to ASCII when making EPS files in an application.
- ❑ For Windows, the printer cannot print binary data when it is connected to the computer using a USB interface. Make sure that ASCII or TBCP is selected as the Output Protocol on the Device Settings tab in the printer's properties.
 - ➔ [“Accessing printer properties for Windows” on page 29](#)

Miscellaneous printout problems

- ❑ For Windows, set the appropriate substitution fonts on the Device Settings tab in the printer's properties dialog box.
 - ➔ [“Accessing printer properties for Windows” on page 29](#)
- ❑ You cannot make color settings on the Paper/Quality tab from printing preferences. Access the printer driver and set the Color Mode on the Advanced Options screen.
 - ➔ [“Accessing the printer driver for Windows” on page 28](#)
 - ➔ [“Accessing the printer driver for Mac OS X” on page 29](#)

Printing takes time

Set the Print Quality to Fast on the Advanced Options menu in the printer driver.

Other Problem

Printing plain papers quietly

When plain paper is selected for the paper type in the printer driver, try choosing Quiet Mode for quieter operations. This will reduce the print speed.

Troubleshooting for Printing

For Windows, select **On** as Quiet Mode in the Main tab of your printer driver.

For Mac OS X, select **On** from the Quiet Mode. To display the Quiet Mode, click through the following menus: **System Preferences, Print & Scan** (for Mac OS X 10.8 or 10.7) or **Print & Fax** (for Mac OS X 10.6 or 10.5), your product (in the Printers list box), **Options & Supplies**, and then **Driver**.

Product Information

System Requirements

For Windows

System	PC Interface
Windows 8 (32-bit, 64-bit), Windows 7 (32-bit, 64-bit), Vista (32-bit, 64-bit), XP SP1 or higher(32-bit), or XP Professional x64 Edition, Server 2012*, Server 2008 R2*, Server 2008*, Server 2003*, and Server 2003 R2*	Hi-Speed USB

* Printer driver only.

For Mac OS X

System	PC Interface
Mac OS X 10.5.8, 10.6.x, 10.7.x, 10.8.x	Hi-Speed USB

Note:

The UNIX File System (UFS) for Mac OS X is not supported.

Technical Specifications

Note:

Specifications are subject to change without notice.

Printer specifications

Paper path	Paper cassette 1 and 2*, front entry Rear paper feed, top entry
Capacity	27.5 mm for paper cassette 0.9 mm for rear paper feed

* Paper cassette 2 is optional.

Product Information

Paper

Note:

- ❑ *Since the quality of any particular brand or type of paper may be changed by the manufacturer at any time, Epson cannot attest to the quality of any non-Epson brand or type of paper. Always test samples of paper stock before purchasing large quantities or printing large jobs.*
- ❑ *Poor quality paper may reduce print quality and cause paper jams or other problems. If you encounter problems, switch to a higher grade of paper.*

Single sheets:

Size	A4 210 × 297 mm B5 182 × 257 mm A5 148 × 210 mm A6 105 × 148 mm 10 × 15 cm (4 × 6 in.) 13 × 18 cm (5 × 7 in.) 16:9 wide size (102 × 181 mm) Letter 8 1/2 × 11 in. Legal 8 1/2 × 14 in. Executive 7 1/4 × 10 1/2 in.
Paper types	Plain paper or special paper distributed by Epson
Thickness (for plain paper)	0.08 to 0.11 mm (0.003 to 0.004 in.)
Weight (for plain paper)	64 g/m ² (17 lb) to 90 g/m ² (24 lb)

Envelopes:

Size	Envelope #10 4 1/8 × 9 1/2 in. Envelope DL 110 × 220 mm Envelope C4 229 × 324 mm Envelope C6 114 × 162 mm
Paper types	Plain paper
Weight	75 g/m ² (20 lb) to 90 g/m ² (24 lb) for Envelope #10, DL, and C6 80 g/m ² (21 lb) to 100 g/m ² (26 lb) for Envelope C4

Printable area

Highlighted portions show printable area.

Product Information

Single sheets:

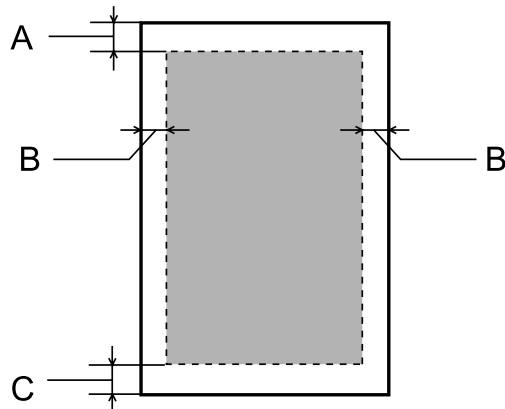

Envelopes:

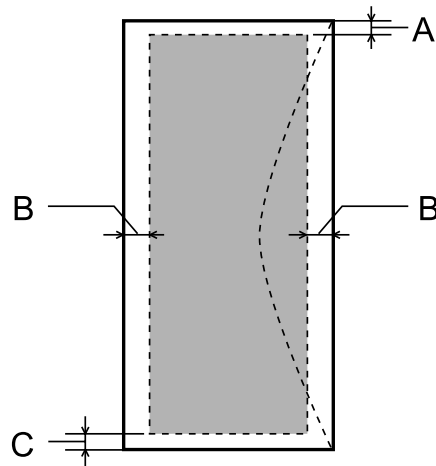

Media type	Minimum margin		
	Single sheets	Envelopes (#10/DL/C6)	Envelop (C4)
A	3.0 mm (0.12 in.)	3.0 mm (0.12 in.)* ¹	3.0 mm (0.12 in.)* ¹
B	3.0 mm (0.12 in.)	5.0 mm (0.20 in.)	9.5 mm (0.38 in.)
C	3.0 mm (0.12 in.)	3.0 mm (0.12 in.)* ²	3.0 mm (0.12 in.)* ²

*1 The recommended margin is 48 mm.

*2 The recommended margin is 21 mm.

Note:
Depending on the type of paper, print quality may decline in the top and bottom areas of the print, or the area may be smeared.

Product Information

Network interface specification

Wi-Fi	Standard:	IEEE 802.11b/g/n* ¹	
	Security:	WEP (64/128bit) WPA-PSK (AES) * ² WPA2-Enterprise	
	Frequency Band:	2.4 GHz	
	Communication Mode:	Infrastructure Ad hoc Wi-Fi Direct* ³	
Ethernet	Standard:	IEEE802.3i/u/ab, IEEE802.3az* ⁴	
	Communication Mode:	1000BASE-T* ⁵ /100BASE-TX/10BASE-T	
Security Protocol	IEEE802.1X		
	IPsec / IP Filtering		
	SSL / TLS	HTTPS Server/Client	
		IPPS	
	SNMPv3		

*1 Complies with either IEEE 802.11b/g/n or IEEE 802.11b/g depending on location of purchase.

*2 Complies with WPA2 with support for WPA/WPA2 Personal.

*3 You can use the product in Simple AP mode of Wi-Fi Direct even if you connect it to an Ethernet network.

*4 The connected device should comply with IEEE802.3az.

*5 Use a category 5e or higher STP (Shielded twisted pair) cable to prevent risk of radio interference.

Mechanical

WF-5110 Series

Dimensions	Storage Width: 461 mm (18.1 inches) Depth: 422 mm (16.6 inches) Height: 284mm (11.2 inches)
	Printing* Width: 461 mm (18.1 inches) Depth: 655 mm (25.8 inches) Height: 383 mm (15.1 inches)
Weight	Approx. 11.3 kg (24.9 lb) without the ink cartridges and the power cord.

* With the output tray extension extended.

WF-5190 Series

Product Information

Dimensions	Storage Width: 461 mm (18.1 inches) Depth: 422 mm (16.6 inches) Height: 284mm (11.2 inches)
	Printing* Width: 461 mm (18.1 inches) Depth: 655 mm (25.8 inches) Height: 383 mm (15.1 inches)
Weight	Approx. 11.4 kg (25.1 lb) without the ink cartridges and the power cord.

* With the output tray extension extended.

Electrical

WF-5110 Series

		100-240 V Model	220-240 V Model
Input voltage range		90 to 264 V	198 to 264 V
Rated frequency range		50 to 60 Hz	50 to 60 Hz
Input frequency range		49.5 to 60.5 Hz	49.5 to 60.5 Hz
Rated current		0.8 to 0.4 A	0.4 A
Power consumption (with USB connection)	Printing	Approx. 24 W (ISO/ IEC24712)	Approx. 24 W (ISO/ IEC24712)
	Ready mode	Approx. 5.5 W	Approx. 5.5 W
	Sleep mode	Approx. 1.6 W	Approx. 1.7 W
	Power off	Approx. 0.3 W	Approx. 0.4 W

WF-5190 Series

		100-240 V Model	220-240 V Model
Input voltage range		90 to 264 V	198 to 264 V
Rated frequency range		50 to 60 Hz	50 to 60 Hz
Input frequency range		49.5 to 60.5 Hz	49.5 to 60.5 Hz
Rated current		0.8 to 0.4 A	0.4 A
Power consumption (with USB connection)	Printing	Approx. 25 W (ISO/ IEC24712)	Approx. 25 W (ISO/ IEC24712)
	Ready mode	Approx. 6.2 W	Approx. 6.3 W
	Sleep mode	Approx. 2.3 W	Approx. 2.4 W
	Power off	Approx. 0.3 W	Approx. 0.4 W

Product Information

Note:

Check the label on the back of the product for its voltage.

Environmental

Temperature	Operation: 10 to 35 °C (50 to 95 °F) Storage: -20 to 40 °C (-4 to 104 °F) 1 month at 40 °C (104 °F)
Humidity	Operation:* 20 to 80% RH Storage:* 5 to 85% RH

* Without condensation

Standards and approvals

U.S. model:

Safety	UL60950-1 CAN/CSA-C22.2 No.60950-1
EMC	FCC Part 15 Subpart B Class B CAN/CSA-CEI/IEC CISPR 22 Class B

This equipment contains the following wireless module.

Manufacture: Askey Computer Corporation

Type: WLU6117-D69 (RoHS)

This product conforms to Part 15 of the FCC Rules and RSS-210 of the IC Rules. Epson cannot accept responsibility for any failure to satisfy the protection requirements resulting from a non-recommended modification of the product. Operation is subject to the following two conditions: (1) this device may not cause harmful interference, and (2) this device must accept any interference received, including interference that may cause undesired operation of the device.

To prevent radio interference to the licensed service, this device is intended to be operated indoors and away from windows to provide maximum shielding. Equipment (or its transmit antenna) that is installed outdoors is subject to licensing.

European model:

Low voltage directive 2006/95/EC	EN60950-1
EMC directive 2004/108/EC	EN55022 Class B EN61000-3-2 EN61000-3-3 EN55024

Product Information

R&TTE directive 1999/5/EC	EN300 328 EN301 489-1 EN301 489-17 EN60950-1
--------------------------------------	---

For European users:

We, Seiko Epson Corporation, hereby declare that the equipment Model B561A and B561B are in compliance with the essential requirements and other relevant provisions of Directive 1999/5/EC.

For use only in Ireland, UK, Austria, Germany, Liechtenstein, Switzerland, France, Belgium, Luxembourg, Netherlands, Italy, Portugal, Spain, Denmark, Finland, Norway, Sweden, Iceland, Cyprus, Greece, Slovenia, Malta, Bulgaria, Czech, Estonia, Hungary, Latvia, Lithuania, Poland, Romania, and Slovakia.

Epson can not accept responsibility for any failure to satisfy the protection requirements resulting a non-recommended modification of the products.



Australian model:

EMC	AS/NZS CISPR22 Class B
------------	------------------------

Epson hereby declares that the equipment Models, B561B is in compliance with the essential requirements and other relevant provisions of AS/NZS4268. Epson cannot accept responsibility for any failure to satisfy the protection requirements resulting from a non-recommended modification of the product.

Interface

Hi-Speed USB (Device Class for computers)

Option

250-Sheet Paper Cassette Unit/PXBACU1

You can use the following 250-Sheet Paper Cassette Unit/PXBACU1.

	Part number
250-Sheet Paper Cassette Unit/PXBACU1	C12C817011

Font Information

Font information for the WF-5190 Series only.

Available fonts

The fonts provided with the printer are shown below, according to the Printing Language mode.

PS 3 mode

Font Name
Albertus, Albertus Italic, Albertus Light
AntiqueOlive Roman, AntiqueOlive Italic, AntiqueOlive Bold, AntiqueOlive Compact
Apple Chancery
ITC AvantGarde Gothic Book, ITC AvantGarde Gothic Book Oblique, ITC AvantGarde Gothic Demi, ITC AvantGarde Gothic Demi Oblique
Bodoni, Bodoni Italic, Bodoni Bold, Bodoni Bold Italic, Bodoni Poster, Bodoni Poster Compressed
ITC Bookman Light, ITC Bookman Light Italic, ITC Bookman Demi, ITC Bookman Demi Italic
Carta
Chicago
Clarendon, Clarendon Light, Clarendon Bold
CooperBlack, CooperBlack Italic
Copperplate Gothic 32BC, Copperplate Gothic 33BC
Coronet
Courier, Courier Oblique, Courier Bold, Courier Bold Oblique
GillSans, GillSans Italic, GillSans Bold, GillSans Bold Italic, GillSansCondensed, GillSans Condensed Bold, GillSans Light, GillSans Light Italic, GillSans Extra Bold
Eurostile, Eurostile Bold, Eurostile Extended Two, Eurostile Bold Extended Two
Geneva
Goudy Oldstyle, Goudy Oldstyle Italic, Goudy Bold, Goudy BoldItalic, Goudy ExtraBold
Helvetica, Helvetica Oblique, Helvetica Bold, Helvetica Bold Oblique, Helvetica Condensed, Helvetica Condensed Oblique, Helvetica Condensed Bold, Helvetica Condensed Bold Oblique, Helvetica Narrow, Helvetica Narrow Oblique, Helvetica Narrow Bold, Helvetica Narrow Bold Oblique
Hoefler Text, Hoefler Text Italic, Hoefler Text Black, Hoefler Text Black Italic, Hoefler Text Ornaments
Joanna, Joanna Italic, Joanna Bold, Joanna Bold Italic
LetterGothic, LetterGothic Slanted, LetterGothic Bold, LetterGothic Bold Slanted
ITC Lubalin Graph Book, ITC Lubalin Graph Book Oblique, ITC Lubalin Graph Demi, ITC Lubalin Graph Demi Oblique
Marigold
Monaco
ITC Mona Lisa Recut

Product Information

Font Name
New Century Schoolbook Roman, New Century Schoolbook Italic, New Century Schoolbook Bold, New Century Schoolbook Bold Italic
New York
Optima, Optima Italic, Optima Bold, Optima Bold Italic
Oxford
Palatino Roman, Palatino Italic, Palatino Bold, Palatino Bold Italic
Stempel Garamond Roman, Stempel Garamond Italic, Stempel Garamond Bold, Stempel Garamond Bold Italic
Symbol
Tekton
Times Roman, Times Italic, Times Bold, Times Bold Italic
Univers, Univers Oblique, Univers Bold, Univers Bold Oblique, Univers Light, Univers Light Oblique
UniversCondensed, UniversCondensed Oblique, UniversCondensed Bold, UniversCondensed Bold Oblique
UniversExtended, UniversExtended Oblique, UniversExtended Bold, UniversExtended Bold Oblique
Wingdings
ITC ZapfChancery Medium Italic
ITC ZapfDingbats
Arial, Arial Italic, Arial Bold, Arial Bold Italic
Times New Roman, Times New Roman Italic, Times New Roman Bold, Times New Roman Bold Italic

PCL5 mode

For symbol set, see [“In the PCL5 mode” on page 114](#).

Scalable Font

Font Name	Family	HP Equivalent	Symbol Set
FixedPitch 810	Medium, Bold, Italic, Bold Italic	Courier	*1
FixedPitch 850	Regular, Bold, Italic	Letter Gothic	*1
FixedPitch 810 Dark	Medium, Bold, Italic, Bold Italic	CourierPS	*3
Dutch 801	Medium, Bold, Italic, Bold Italic	CG Times	*2
Zapf Humanist 601	Medium, Bold, Italic, Bold Italic	CG Omega	*3
Ribbon 131	-	Coronet	*3
Clarendon 701	-	Clarendon Condensed	*3
Swiss 742	Medium, Bold, Italic, Bold Italic	Univers	*2

Product Information

Font Name	Family	HP Equivalent	Symbol Set
Swiss 742 Condensed	Medium, Bold, Italic, Bold Italic	Univers Condensed	*3
Incised 901	Medium, Bold, Italic	Antique Olive	*3
Aldine 430	Medium, Bold, Italic, Bold Italic	Garamond	*3
Calligraphic 401	-	Marigold	*3
Flareserif 821	Medium, Extra Bold	Albertus	*3
Swiss 721 SWM	Medium, Bold, Italic, Bold Italic	Arial	*3
Dutch 801 SWM	Medium, Bold, Italic, Bold Italic	Times New	*3
Swiss 721 SWA	Medium, Bold, Oblique, Bold Oblique	Helvetica	*3
Swiss 721 Narrow SWA	Medium, Bold, Oblique, Bold Oblique	Helvetica Narrow	*3
Zapf Calligraphic 801 SWA	Medium, Bold, Italic, Bold Italic	Palatino	*3
Geometric 711 SWA	Medium, Bold, Oblique, Bold Italic	ITC Avant Garde Gothic	*3
Revival 711 SWA	Light, Demi Bold, Light Italic, Demi Bold Italic	ITC Bookman	*3
Century 702 SWA	Medium, Bold, Italic, Bold Italic	New Century Schoolbook	*3
Dutch 801 SWA	Medium, Bold, Italic, Bold Italic	Times	*3
Chancery 801 Medium SWA Italic	-	ITC Zapf Chancery Medium Italic	*3
Symbol SWM	-	Symbol	*4
More WingBats SWM	-	Wingdings	*5
Ding Dings SWA	-	ITC Zapf Dingbats	*6
Symbol SWA	-	SymbolPS	*4
David BT	Medium, Bold	David	*7
Narkis Tam BT	Medium, Bold	Narkis	*7
Miryam BT	Medium, Bold, Italic	Miryam	*7
Koufi BT	Medium, Bold	Koufi	*8
Naskh BT	Medium, Bold	Naskh	*8
Ryadh BT	Medium, Bold	Ryadh	*8

Bitmap Font

Font Name	Symbol Set
Line Printer	*9

Product Information

OCR/BarCode Bitmap Font

Font Name	Family	Symbol Set
OCR A	-	*10
OCR B	-	*11
Code39	9.37cpi, 4.68cpi	*12
EAN/UPC	Medium, Bold	*13

Note:

Depending on the print density, or on the quality or color of the paper, OCR A, OCR B, Code39, and EAN/UPC fonts may not be readable. Print a sample and make sure the fonts can be read before printing large quantities.

PCL6 mode

For symbol set, see [“In the PCL6 Mode”](#) on page 116.

Scalable Font

Font Name	Family	HP Equivalent	Symbol Set
FixedPitch 810	Medium, Bold, Italic, Bold Italic	Courier	*1
FixedPitch 850	Regular, Bold, Italic	Letter Gothic	*1
FixedPitch 810 Dark	Medium, Bold, Italic, Bold Italic	CourierPS	*3
Dutch 801	Medium, Bold, Italic, Bold Italic	CG Times	*2
Zapf Humanist 601	Medium, Bold, Italic, Bold Italic	CG Omega	*3
Ribbon 131	-	Coronet	*3
Clarendon 701	-	Clarendon Condensed	*3
Swiss 742	Medium, Bold, Italic, Bold Italic	Univers	*2
Swiss 742 Condensed	Medium, Bold, Italic, Bold Italic	Univers Condensed	*3
Incised 901	Medium, Bold, Italic	Antique Olive	*3
Aldine 430	Medium, Bold, Italic, Bold Italic	Garamond	*3
Calligraphic 401	-	Marigold	*3
Flareserif 821	Medium, Extra Bold	Albertus	*3
Swiss 721 SWM	Medium, Bold, Italic, Bold Italic	Arial	*3
Dutch 801 SWM	Medium, Bold, Italic, Bold Italic	Times New	*3
Swiss 721 SWA	Medium, Bold, Oblique, Bold Oblique	Helvetica	*3

Product Information

Font Name	Family	HP Equivalent	Symbol Set
Swiss 721 Narrow SWA	Medium, Bold, Oblique, Bold Oblique	Helvetica Narrow	*3
Zapf Calligraphic 801 SWA	Medium, Bold, Italic, Bold Italic	Palatino	*3
Geometric 711 SWA	Medium, Bold, Oblique, Bold Italic	ITC Avant Garde Gothic	*3
Revival 711 SWA	Light, Demi Bold, Light Italic, Demi Bold Italic	ITC Bookman	*3
Century 702 SWA	Medium, Bold, Italic, Bold Italic	New Century Schoolbook	*3
Dutch 801 SWA	Medium, Bold, Italic, Bold Italic	Times	*3
Chancery 801 Medium SWA Italic	-	ITC ZapfChancery Medium Italic	*3
Symbol SWM	-	Symbol	*4
More WingBats SWM	-	Wingdings	*5
Ding Dings SWA	-	ITC Zapf Dingbats	*6
Symbol SWA	-	SymbolPS	*4
David BT	Medium, Bold	David	*7
Narkis Tam BT	Medium, Bold	Narkis	*7
Miryam BT	Medium, Bold, Italic	Miryam	*7
Koufi BT	Medium, Bold	Koufi	*8
Naskh BT	Medium, Bold	Naskh	*8
Ryadh BT	Medium, Bold	Ryadh	*8

Bitmap Font

Font Name	Symbol Set
Line Printer	*9

Introduction to symbol sets

Your printer can access a variety of symbol sets. Many of these symbol sets differ only in the international characters specific to each language.

Note:

Since most software handles fonts and symbols automatically, you will probably never need to adjust the printer's settings. However, if you are writing your own printer control programs, or if you are using older software that cannot control fonts, refer to the following sections for symbol set details.

When you are considering which font to use, you should also consider which symbol set to combine with the font.

Product Information

In the PCL5 mode

Symbol Set Name	Attribute	Font Classification												
		*1	*2	*3	*4	*5	*6	*7	*8	*9	*10	*11	*12	*13
ISO 60: Danish/Norwegian	0D	○	○	○	-	-	-	-	-	-	-	-	-	-
Roman Extension	0E	-	-	-	-	-	-	-	-	○	-	-	-	-
ISO 15: Italian	0I	○	○	○	-	-	-	-	-	-	-	-	-	-
ISO 8859/1 Latin 1	0N	○	○	○	-	-	-	-	-	○	-	-	-	-
ISO 11: Swedish	0S	○	○	○	-	-	-	-	-	-	-	-	-	-
ISO 6: ASCII	0U	○	○	○	-	-	-	○	○	-	-	-	-	-
ISO 4: United Kingdom	1E	○	○	○	-	-	-	-	-	-	-	-	-	-
ISO 69: French	1F	○	○	○	-	-	-	-	-	-	-	-	-	-
ISO 29: German	1G	○	○	○	-	-	-	-	-	-	-	-	-	-
Legal	1U	○	○	○	-	-	-	-	-	○	-	-	-	-
ISO 8859/2 Latin 2	2N	○	○	○	-	-	-	-	-	○	-	-	-	-
ISO 17: Spanish	2S	○	○	○	-	-	-	-	-	-	-	-	-	-
ISO 8859/4 Latin 4	4N	○	○	○	-	-	-	-	-	-	-	-	-	-
Roman-9	4U	○	○	○	-	-	-	-	-	-	-	-	-	-
PS Math	5M	○	○	○	-	-	-	○	○	-	-	-	-	-
ISO 8859/9 Latin 5	5N	○	○	○	-	-	-	-	-	○	-	-	-	-
Windows 3.1 Latin 5	5T	○	○	○	-	-	-	-	-	-	-	-	-	-
Microsoft Publishing	6J	○	○	○	-	-	-	-	-	-	-	-	-	-
Ventura Math	6M	○	○	○	-	-	-	-	-	-	-	-	-	-
ISO 8859/10 Latin 6	6N	○	○	○	-	-	-	-	-	○	-	-	-	-
DeskTop	7J	○	○	○	-	-	-	-	-	-	-	-	-	-
Math-8	8M	○	○	○	-	-	-	○	○	-	-	-	-	-
Roman-8	8U	○	○	○	-	-	-	-	-	○	-	-	-	-
Windows 3.1 Latin 2	9E	○	○	○	-	-	-	-	-	-	-	-	-	-
Pc1004	9J	○	○	○	-	-	-	-	-	-	-	-	-	-
ISO 8859/15 Latin 9	9N	○	○	○	-	-	-	-	-	○	-	-	-	-
PC-8 Turkish	9T	○	○	○	-	-	-	-	-	-	-	-	-	-

Product Information

Symbol Set Name	Attribute	Font Classification												
		*1	*2	*3	*4	*5	*6	*7	*8	*9	*10	*11	*12	*13
Windows 3.0 Latin 1	9U	○	○	○	-	-	-	-	-	-	-	-	-	-
PS Text	10J	○	○	○	-	-	-	-	-	-	-	-	-	-
PC-8, Code Page 437	10U	○	○	○	-	-	-	-	-	○	-	-	-	-
PC-8, D/N, Danish/ Norwegian	11U	○	○	○	-	-	-	-	-	○	-	-	-	-
MC Text	12J	○	○	○	-	-	-	-	-	-	-	-	-	-
PC-850, Multilingual	12U	○	○	○	-	-	-	-	-	○	-	-	-	-
Ventura International	13J	○	○	○	-	-	-	-	-	-	-	-	-	-
PcEur858	13U	○	○	○	-	-	-	-	-	-	-	-	-	-
Ventura US	14J	○	○	○	-	-	-	-	-	-	-	-	-	-
Pi Font	15U	○	○	○	-	-	-	-	-	-	-	-	-	-
PC852, Latin 2	17U	○	○	○	-	-	-	-	-	-	-	-	-	-
Unicode 3.0	18N	○	○	○	-	-	-	○	○	-	-	-	-	-
Windows Baltic	19L	○	○	○	-	-	-	-	-	-	-	-	-	-
Windows 3.1 Latin/Arabic	19U	○	○	○	-	-	-	-	-	-	-	-	-	-
PC-755	26U	○	○	○	-	-	-	-	-	-	-	-	-	-
PC-866, Cyrillic	3R	○	○	-	-	-	-	-	-	-	-	-	-	-
Greek8	8G	○	○	-	-	-	-	-	-	-	-	-	-	-
Windows Greek	9G	○	○	-	-	-	-	-	-	-	-	-	-	-
Windows Cyrillic	9R	○	○	-	-	-	-	-	-	-	-	-	-	-
PC-851, Greek	10G	○	○	-	-	-	-	-	-	-	-	-	-	-
ISO 8859/5 Cyrillic	10N	○	○	-	-	-	-	-	-	○	-	-	-	-
PC-8, Greek	12G	○	○	-	-	-	-	-	-	-	-	-	-	-
ISO 8859/7 Greek	12N	○	○	-	-	-	-	-	-	-	-	-	-	-
PC-866 UKR	14R	○	○	-	-	-	-	-	-	-	-	-	-	-
Hebrew7	0H	○	-	-	-	-	-	○	-	-	-	-	-	-
ISO 8859/8 Hebrew	7H	○	-	-	-	-	-	○	-	-	-	-	-	-
Hebrew8	8H	○	-	-	-	-	-	○	-	-	-	-	-	-
PC-862, Hebrew	15H	○	-	-	-	-	-	○	-	-	-	-	-	-

Product Information

Symbol Set Name	Attribute	Font Classification													
		*1	*2	*3	*4	*5	*6	*7	*8	*9	*10	*11	*12	*13	
PC-862, Hebrew	15Q	○	-	-	-	-	-	-	○	-	-	-	-	-	-
Arabic8	8V	-	-	-	-	-	-	-	-	○	-	-	-	-	-
HPWARA	9V	-	-	-	-	-	-	-	-	○	-	-	-	-	-
PC-864, Arabic	10V	-	-	-	-	-	-	-	-	○	-	-	-	-	-
Symbol	19M	-	-	-	○	-	-	-	-	-	-	-	-	-	-
Wingdings	579L	-	-	-	-	○	-	-	-	-	-	-	-	-	-
ZapfDingbats	14L	-	-	-	-	-	○	-	-	-	-	-	-	-	-
OCR A	00	-	-	-	-	-	-	-	-	-	○	-	-	-	-
OCR B	10	-	-	-	-	-	-	-	-	-	-	○	-	-	-
OCR B Extension	3Q	-	-	-	-	-	-	-	-	-	-	○	-	-	-
Code3-9	0Y	-	-	-	-	-	-	-	-	-	-	-	○	-	-
EAN/UPC	8Y	-	-	-	-	-	-	-	-	-	-	-	-	-	○

In the PCL6 Mode

Symbol Set Name	Attribute	Font Classification								
		*1	*2	*3	*4	*5	*6	*7	*8	*9
ISO Norwegian	4	○	○	○	-	-	-	-	-	-
ISO Italian	9	○	○	○	-	-	-	-	-	-
ISO 8859-1 Latin 1	14	○	○	○	-	-	-	-	-	○
ISO Swedish	19	○	○	○	-	-	-	-	-	-
ASCII	21	○	○	○	-	-	-	○	○	-
ISO United Kingdom	37	○	○	○	-	-	-	-	-	-
ISO French	38	○	○	○	-	-	-	-	-	-
ISO German	39	○	○	○	-	-	-	-	-	-
Legal	53	○	○	○	-	-	-	-	-	○
ISO 8859-2 Latin 2	78	○	○	○	-	-	-	-	-	○
ISO Spanish	83	○	○	○	-	-	-	-	-	-
Roman-9	149	○	○	○	-	-	-	-	-	-

Product Information

Symbol Set Name	Attribute	Font Classification								
		*1	*2	*3	*4	*5	*6	*7	*8	*9
PS Math	173	○	○	○	-	-	-	○	○	-
ISO 8859-9 Latin 5	174	○	○	○	-	-	-	-	-	○
Windows 3.1 Latin 5	180	○	○	○	-	-	-	-	-	-
Microsoft Publishing	202	○	○	○	-	-	-	-	-	-
ISO 8859/10 Latin 6	206	○	○	○	-	-	-	-	-	○
DeskTop	234	○	○	○	-	-	-	-	-	-
Math-8	269	○	○	○	-	-	-	○	○	-
Roman-8	277	○	○	○	-	-	-	-	-	○
Windows 3.1 Latin 2	293	○	○	○	-	-	-	-	-	-
Pc1004	298	○	○	○	-	-	-	-	-	-
ISO 8859-15 Latin 9	302	○	○	○	-	-	-	-	-	-
PC-Turkish	308	○	○	○	-	-	-	-	-	-
Windows 3.0	309	○	○	○	-	-	-	-	-	-
PS Text	330	○	○	○	-	-	-	-	-	-
PC-8	341	○	○	○	-	-	-	-	-	○
PC-8 D/N	373	○	○	○	-	-	-	-	-	○
MC Text	394	○	○	○	-	-	-	-	-	-
PC-850	405	○	○	○	-	-	-	-	-	○
PcEur858	437	○	○	○	-	-	-	-	-	-
Pi Font	501	○	○	○	-	-	-	-	-	-
PC852	565	○	○	○	-	-	-	-	-	-
Unicode 3.0	590	○	○	○	-	-	-	-	-	-
WBALT	620	○	○	○	-	-	-	-	-	-
Windows 3.1 Latin 1	629	○	○	○	-	-	-	-	-	-
PC-755	853	○	○	○	-	-	-	-	-	-
Wingdings	18540	-	-	-	-	○	-	-	-	-
Symbol	621	-	-	-	○	-	-	-	-	-
ZapfDingbats	460	-	-	-	-	-	○	-	-	-

Product Information

Symbol Set Name	Attribute	Font Classification								
		*1	*2	*3	*4	*5	*6	*7	*8	*9
PC-866, Cyrillic	114	○	○	-	-	-	-	-	-	-
Greek8	263	○	○	-	-	-	-	-	-	-
Windows Greek	295	○	○	-	-	-	-	-	-	-
Windows Cyrillic	306	○	○	-	-	-	-	-	-	-
PC-851, Greek	327	○	○	-	-	-	-	-	-	-
ISO 8859/5 Cyrillic	334	○	○	-	-	-	-	-	-	-
PC-8, Greek	391	○	○	-	-	-	-	-	-	-
ISO 8859/7 Greek	398	○	○	-	-	-	-	-	-	-
PC-866 UKR	466	○	○	-	-	-	-	-	-	-
Hebrew7	8	○	-	-	-	-	-	-	-	-
ISO 8859/8 Hebrew	232	○	-	-	-	-	-	○	-	-
Hebrew8	264	○	-	-	-	-	-	○	-	-
PC-862, Hebrew	488	○	-	-	-	-	-	○	-	-
Arabic8	278	-	-	-	-	-	-	-	○	-
HPWARA	310	-	-	-	-	-	-	-	○	-
PC-864, Arabic	342	-	-	-	-	-	-	-	○	-

Where To Get Help

Technical Support Web Site

If you need further help, visit the Epson support website shown below. Select your country or region and go to the support section of your local Epson website. The latest drivers, FAQs, manuals, or other downloadables are also available from the site.

<http://support.epson.net/>

<http://www.epson.eu/Support> (Europe)

If your Epson product is not operating properly and you cannot solve the problem, contact Epson support services for assistance.

Contacting Epson Support

Before Contacting Epson

If your Epson product is not operating properly and you cannot solve the problem using the troubleshooting information in your product documentation, contact Epson support services for assistance. If Epson support for your area is not listed below, contact the dealer where you purchased your product.

Epson support will be able to help you much more quickly if you give them the following information:

- Product serial number
(The serial number label is usually on the back of the product.)
- Product model
- Product software version
(Click **About**, **Version Info**, or similar button in the product software.)
- Brand and model of your computer
- Your computer operating system name and version
- Names and versions of the software applications you normally use with your product

Note:

Depending on the product, the dial list data for fax and/or network settings may be stored in the product's memory. Due to breakdown or repair of a product, data and/or settings may be lost. Epson shall not be responsible for the loss of any data, for backing up or recovering data and/or settings even during a warranty period. We recommend that you make your own backup data or take notes.

Where To Get Help

Help for Users in Europe

Check your **Pan-European Warranty Document** for information on how to contact Epson support.

Help for Users in Taiwan

Contacts for information, support, and services are:

World Wide Web (<http://www.epson.com.tw>)

Information on product specifications, drivers for download, and products enquiry are available.

Epson HelpDesk (Phone: +02-80242008)

Our HelpDesk team can help you with the following over the phone:

- Sales enquiries and product information
- Product usage questions or problems
- Enquiries on repair service and warranty

Repair service center:

Telephone number	Fax number	Address
02-23416969	02-23417070	No.20, Beiping E. Rd., Zhongzheng Dist., Taipei City 100, Taiwan
02-27491234	02-27495955	1F., No.16, Sec. 5, Nanjing E. Rd., Songshan Dist., Taipei City 105, Taiwan
02-32340688	02-32340699	No.1, Ln. 359, Sec. 2, Zhongshan Rd., Zhonghe City, Taipei County 235, Taiwan
039-605007	039-600969	No.342-1, Guangrong Rd., Luodong Township, Yilan County 265, Taiwan
038-312966	038-312977	No.87, Guolian 2nd Rd., Hualien City, Hualien County 970, Taiwan
03-4393119	03-4396589	5F., No.2, Nandong Rd., Pingzhen City, Taoyuan County 32455, Taiwan
03-5325077	03-5320092	1F., No.9, Ln. 379, Sec. 1, Jingguo Rd., North Dist., Hsinchu City 300, Taiwan
04-23011502	04-23011503	3F., No.30, Dahe Rd., West Dist., Taichung City 40341, Taiwan
04-2338-0879	04-2338-6639	No.209, Xinxing Rd., Wuri Dist., Taichung City 414, Taiwan
05-2784222	05-2784555	No.463, Zhongxiao Rd., East Dist., Chiayi City 600, Taiwan
06-2221666	06-2112555	No.141, Gongyuan N. Rd., North Dist., Tainan City 704, Taiwan

Where To Get Help

Telephone number	Fax number	Address
07-5520918	07-5540926	1F., No.337, Minghua Rd., Gushan Dist., Kaohsiung City 804, Taiwan
07-3222445	07-3218085	No.51, Shandong St., Sanmin Dist., Kaohsiung City 807, Taiwan
08-7344771	08-7344802	1F., No.113, Shengli Rd., Pingtung City, Pingtung County 900, Taiwan

Help for Users in Australia

Epson Australia wishes to provide you with a high level of customer service. In addition to your product documentation, we provide the following sources for obtaining information:

Internet URL <http://www.epson.com.au>

Access the Epson Australia World Wide Web pages. Worth taking your modem here for the occasional surf! The site provides a download area for drivers, Epson contact points, new product information and technical support (e-mail).

Epson Helpdesk

Epson Helpdesk is provided as a final backup to make sure our clients have access to advice. Operators on the Helpdesk can aid you in installing, configuring and operating your Epson product. Our Pre-sales Helpdesk staff can provide literature on new Epson products and advise where the nearest dealer or service agent is located. Many types of queries are answered here.

The Helpdesk number is:

Phone: 1300 361 054

We encourage you to have all the relevant information on hand when you ring. The more information you prepare, the faster we can help solve the problem. This information includes your Epson product documentation, type of computer, operating system, application programs, and any information you feel is required.

Help for Users in Singapore

Sources of information, support, and services available from Epson Singapore are:

World Wide Web

<http://www.epson.com.sg>

Information on product specifications, drivers for download, Frequently Asked Questions (FAQ), Sales Enquiries, and Technical Support via e-mail are available.

Epson HelpDesk (Phone: (65) 6586 3111)

Our HelpDesk team can help you with the following over the phone:

Where To Get Help

- Sales enquiries and product information
- Product usage questions or problems
- Enquiries on repair service and warranty

Help for Users in Thailand

Contacts for information, support, and services are:

World Wide Web

<http://www.epson.co.th>

Information on product specifications, drivers for download, Frequently Asked Questions (FAQ), and e-mail are available.

Epson Hotline (Phone: (66) 2685-9899)

Our Hotline team can help you with the following over the phone:

- Sales enquiries and product information
- Product usage questions or problems
- Enquiries on repair service and warranty

Help for Users in Vietnam

Contacts for information, support, and services are:

Epson Hotline (Phone): 84-8-823-9239

Service Center: 80 Truong Dinh Street, District 1, Hochiminh City, Vietnam.

Help for Users in Indonesia

Contacts for information, support, and services are:

World Wide Web

<http://www.epson.co.id>

- Information on product specifications, drivers for download
- Frequently Asked Questions (FAQ), Sales Enquiries, questions through e-mail

Epson Hotline

- Sales enquiries and product information

Where To Get Help

- Technical support

Phone: (62) 21-572 4350

Fax: (62) 21-572 4357

Epson service center

Jakarta	Mangga Dua Mall 3rd floor No 3A/B Jl. Arteri Mangga Dua, Jakarta	Phone/Fax: (62) 21-62301104
Bandung	Lippo Center 8th floor Jl. Gatot Subroto No.2 Bandung	Phone/Fax: (62) 22-7303766
Surabaya	Hitech Mall It IIB No. 12 Jl. Kusuma Bangsa 116-118 Surabaya	Phone: (62) 31-5355035 Fax: (62)31-5477837
Yogyakarta	Hotel Natour Garuda Jl. Malioboro No. 60 Yogyakarta	Phone: (62) 274-565478
Medan	Wisma HSBC 4th floor Jl. Diponegoro No. 11 Medan	Phone/Fax: (62) 61-4516173
Makassar	MTC Karebosi Lt. III Kav. P7-8 Jl. Ahmad Yani No.49 Makassar	Phone: (62)411-350147/411-350148

Help for Users in Malaysia

Contacts for information, support, and services are:

World Wide Web

<http://www.epson.com.my>

- Information on product specifications, drivers for download
- Frequently Asked Questions (FAQ), Sales Enquiries, questions through e-mail

Epson Trading (M) Sdn. Bhd.

Head Office:

Phone: 603-56288288

Fax: 603-56288388/399

Where To Get Help

Epson Helpdesk:

- Sales enquiries and product information (Infoline)
Phone: 603-56288222
- Enquiries on repair services & warranty, product usage and technical support (Techline)
Phone: 603-56288333

Help for Users in the Philippines

To obtain technical support as well as other after sales services, users are welcome to contact the Epson Philippines Corporation at the telephone and fax numbers and e-mail address below:

Trunk Line: (63-2) 706 2609

Fax: (63-2) 706 2665

Helpdesk Direct Line: (63-2) 706 2625

E-mail: epchelpdesk@epc.epson.com.ph

World Wide Web

<http://www.epson.com.ph>

Information on product specifications, drivers for download, Frequently Asked Questions (FAQ), and E-mail Enquiries are available.

Toll-Free No. 1800-1069-EPSON (37766)

Our Hotline team can help you with the following over the phone:

- Sales enquiries and product information
- Product usage questions or problems
- Enquiries on repair service and warranty

Index**2**

2-Sided Printing.....	48
2-sided printing.....	36

A

A4/Letter Auto Switching.....	46
Admin Password.....	45
Administrator settings.....	43
Advanced Setup.....	47
Aligning print head.....	69
Anti-Copy Pattern printing.....	40
Auto Error Solver.....	46
Auto Paper Ejection.....	48
Auto Select Settings.....	46

B

Banding.....	93
Binary.....	50
Binding Margin.....	48
Blank pages.....	96
Blurry prints.....	94

C

Canceling printing.....	34
Mac OS X.....	34
Windows.....	34
Check Paper Width.....	48
Cleaning	
print head.....	67
Clear Internal Memory Data.....	50
Color problems.....	94
Coloration.....	50
Common Settings.....	47, 48
Confidential Job.....	45
Confidential Job Printing.....	42
Configuration Status Sheet.....	45
Connection Check.....	47
Contacting Epson.....	119
Copyright.....	2
CR Function.....	49

D

Date/Time.....	47
Date/Time Settings.....	47
Daylight Saving Time.....	47
Delete All Confidential Jobs.....	50
Disable Wi-Fi.....	47
Documents	
printing.....	30
Driver	

accessing for Mac OS X.....	29
accessing for Windows.....	28
uninstalling.....	81
Dry Time.....	48

E

Eco Mode.....	50
Enlarging pages.....	38
Envelopes	
loading.....	25
printable area.....	104
Epson	
paper.....	18
Epson Connect.....	10
Epson Connect Services.....	47
Error messages.....	84
Error Notice.....	46
Error Sheet.....	50
Errors	
print.....	85

F

Fit to page printing.....	38
Font.....	108
Font Number.....	49
Font Source.....	49
Fonts	
PCL5 mode.....	110
PCL6 mode.....	112
PS 3 mode.....	109
Form.....	49

G

Google Cloud Print Services.....	47
----------------------------------	----

H

Head cleaning	
control panel.....	68
Mac OS X.....	68
Windows.....	68
Header/Footer printing.....	42
Height.....	49
Help	
Epson.....	119
Horizontal Alignment.....	45
Horizontal banding.....	93

I

Icons.....	16
Image Protect.....	50

Index

Incorrect characters.....	95
Ink	
BK printing.....	57
BK printing in Mac.....	59
BK printing in Windows.....	57
checking ink cartridge status in Mac OS X.....	55
checking ink cartridge status in Windows.....	54
checking ink cartridge status using the control panel.....	56
precaution.....	52
saving black ink in Windows.....	60
temporarily printing with black ink.....	57
Ink cartridges	
replacing when expended.....	61
Ink Levels.....	45
Ink Save Mode.....	48
Interface cables.....	108

L

Language.....	47
LCD Contrast.....	47
Left Offset.....	48
Left Offset in Back.....	48
LF Function.....	49
Loading	
paper.....	18, 22, 25
Lock Settings.....	45

M

Mac OS X	
accessing printer settings.....	29
checking product status.....	87
Maintenance.....	45
Maintenance box.....	73
Managing print jobs	
Windows.....	86
Manual feed.....	25
Margins	
problems.....	95
Mirror image.....	96
Misalignment.....	93
Multiple pages per sheet.....	39

N

Network Status.....	45
Nozzle check.....	65
control panel.....	66
Mac OS X.....	66
Windows.....	65
Number of Copies.....	48

O

Orientation.....	48
------------------	----

P

Pages per sheet printing.....	39
Paper	
Epson special paper.....	18
feeding problems.....	97
jams.....	88
loading.....	22, 25
loading capacity.....	18
printable area.....	103
specifications.....	103
wrinkling.....	98
Paper cassette	
installing.....	64
uninstalling.....	65
Paper Guide Cleaning.....	45
Paper Setup.....	45
Paper Size.....	48
Paper Size Notice.....	46
Paper Source Assign.....	49
Paper Source Settings.....	46
Paper Type.....	48
Paper Type Notice.....	46
PC Connection via USB.....	46
PCL.....	80, 108
PCL Font List.....	45
PCL Menu.....	49
PCL5 mode.....	110
PCL6 mode.....	112, 116
PDF Page Size.....	50
PDL Print Configuration.....	48
PIN Code Setup (WPS).....	47
Pitch.....	49
PostScript.....	108
Power Off Timer.....	47, 50
Print head	
aligning.....	69
checking.....	65
cleaning.....	67
Print Head Alignment.....	45
Print Head Cleaning.....	45
Print Head Nozzle Check.....	45
Print Order.....	48
Print quality	
improving.....	92
Print speed	
increasing.....	97
Print Status Sheet.....	45
Printable area specifications.....	104
Printer Settings.....	46
Printing	
2-sided.....	36
canceling.....	34
fit to page.....	38
multiple pages per sheet.....	39
preset.....	35
shortcut.....	35
text.....	30
Printing Language.....	46
Problems	
banding.....	93
blank pages.....	96
blurry prints.....	94

Index

- contacting Epson.....119
 - diagnosing.....85
 - incorrect characters.....95
 - incorrect colors.....94
 - margins.....95
 - mirror image.....96
 - paper feeding.....97
 - paper jams.....88
 - print.....85
 - print speed.....97
 - product does not print.....99
 - smear prints.....94, 96
 - solving.....119
 - Product
 - checking status.....86
 - cleaning.....72
 - parts.....14
 - transporting.....75
 - Product settings
 - accessing for Mac OS X.....29
 - accessing for Windows.....28
 - PS 3 mode.....109
 - PS3.....77, 99
 - PS3 Font List.....45
 - PS3 Menu.....50
 - PS3 Status Sheet.....45
 - Push Button Setup (WPS).....47
- Q**
- Quality.....48
- R**
- Rear Paper Feed Priority.....46
 - Reducing page size.....38
 - Replacing ink cartridges.....61
 - Resizing pages.....38
 - Restore Default Settings.....50
 - Ruled Line Alignment.....45
- S**
- Safety information.....11
 - Scroll Speed.....47
 - Security Settings.....45, 50
 - Service.....119
 - Skip Blank Page.....48
 - Sleep Timer.....47, 50
 - Smear prints.....94, 96
 - Software
 - uninstalling.....81
 - Specifications
 - mechanical.....105
 - paper.....103
 - printer.....102
 - standards and approvals.....107
 - Speed
 - increasing.....97
 - Status Monitor
 - Mac OS X.....87
 - Supply Status Sheet.....45
 - Symbol Set.....49
 - Symbol sets
 - introduction.....113
 - PCL6 mode.....116
 - System Administration.....45
 - System requirements.....102
- T**
- Technical support.....119
 - Text
 - printing documents.....30
 - Text Detection.....50
 - Thick Paper.....45
 - Time Difference.....47
 - Top Offset.....48
 - Top Offset in Back.....48
 - Trademarks.....2
 - Transporting product.....75
- U**
- Universal Print Settings.....48
 - Usage History Sheet.....45
 - USB
 - connector.....108
 - USB I/F Timeout Setting.....46
- V**
- Vertical Alignment.....45
- W**
- Watermark printing.....41
 - Web service.....10
 - Wi-Fi Auto Connect.....47
 - Wi-Fi Direct Setup.....47
 - Wi-Fi Setup.....47
 - Wi-Fi Setup Wizard.....47
 - Wi-Fi/Network Settings.....47
 - Wi-Fi/Network Status.....47
 - Windows
 - accessing printer settings.....28
 - checking product status.....86
 - managing print jobs.....86